

Hydro-Pneumatic Pumps

Basic Dimensions

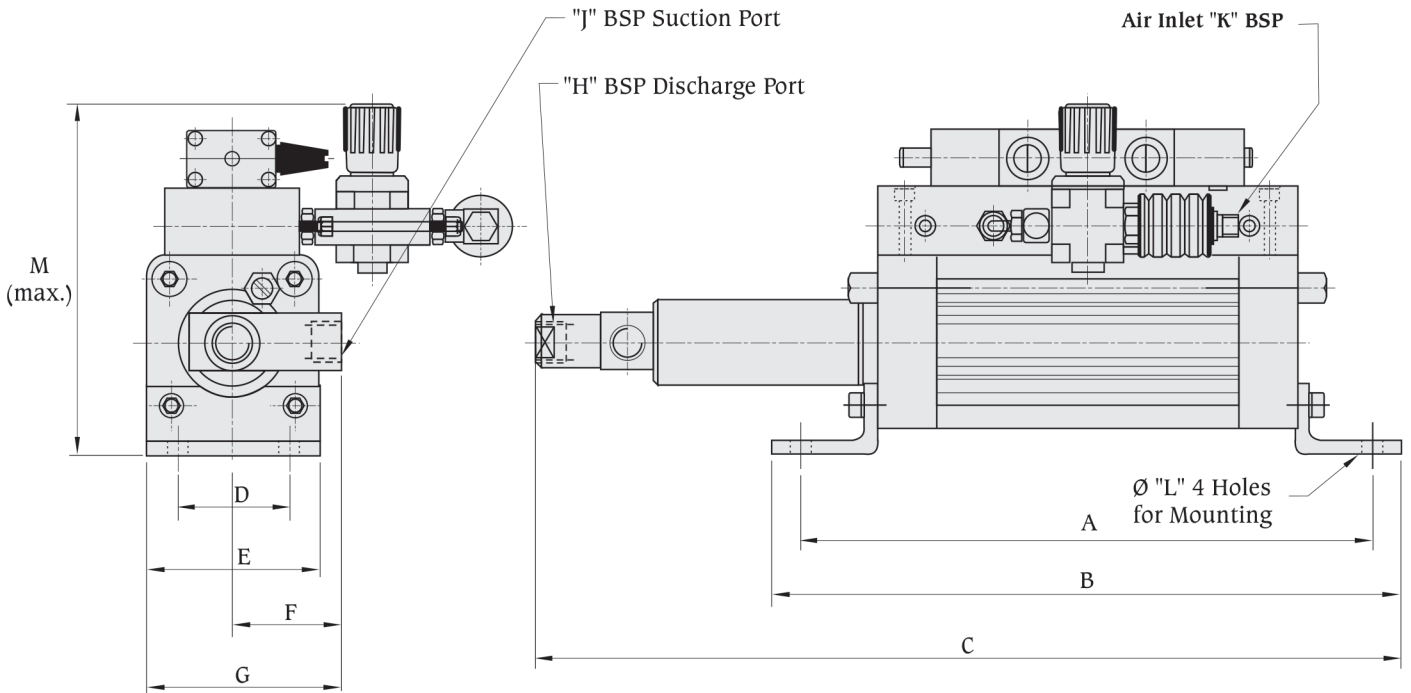

All dimensions in mm

Model No.	Ratio	Output Pressure kg/cm ²	A	B	C	D	E	F	G	H BSP	J BSP	K BSP	L	M	Free Discharge Litres/min. (Appx.)	Free Air Consumption Litres/min. (Appx.)
80-10-S	64.0	320	320	354	494	63	99	68	117	1/2"	1/2"	1/4"	12	197	1.57	985
80-14-S	32.0	160	320	354	494	63	99	68	117	1/2"	1/2"	1/4"	12	197	2.76	985
80-16-S	25.0	125	320	354	494	63	99	68	117	1/2"	1/2"	1/4"	12	197	3.5	985
80-20-S	16.0	80	320	354	494	63	99	68	117	1/2"	1/2"	1/4"	12	197	5.0	985
80-25-S	10.0	50	320	354	494	63	99	68	117	1/2"	1/2"	1/4"	12	197	6.9	985
80-28-S	8.0	40	320	354	494	63	99	68	117	1/2"	1/2"	1/4"	12	197	7.9	985
100-10-S	100.0	500	320	348	491	75	128	68	132	1/2"	1/2"	1/4"	14	219	1.2	1150
100-14-S	51.0	255	320	348	491	75	128	68	132	1/2"	1/2"	1/4"	14	219	2.0	1150
100-16-S	40.0	200	320	348	491	75	128	68	132	1/2"	1/2"	1/4"	14	219	2.6	1150
100-20-S	25.0	125	320	348	491	75	128	68	132	1/2"	1/2"	1/4"	14	219	3.7	1150
100-28-S	12.75	64	320	348	491	75	128	68	132	1/2"	1/2"	1/4"	14	219	6.0	1150
100-32-S	9.75	48	320	348	491	75	128	68	132	1/2"	1/2"	1/4"	14	219	6.72	1150
160-32-S	25.0	125	320	360	491	130	186	68	161	1/2"	1/2"	1/2"	17	263	3.6	905
160-40-S	16.0	80	320	360	491	130	186	68	161	3/4"	3/4"	1/2"	17	263	5.7	905
160-56-S	8.0	40	320	360	491	130	186	68	161	3/4"	3/4"	1/2"	17	263	11.0	905
160-14-D	260.0	1300	521	561	691	130	186	68	161	1/2"	1/2"	1/2"	17	263	0.5	1350
160-20-D	128.0	640	521	561	691	130	186	68	161	1/2"	1/2"	1/2"	17	263	1.0	1350

Note : Subject to change without prior notice

