

FIBROMAT HEAVY-LOAD POSITIONING TABLES

DATA SHEET

 **COLLECTION**

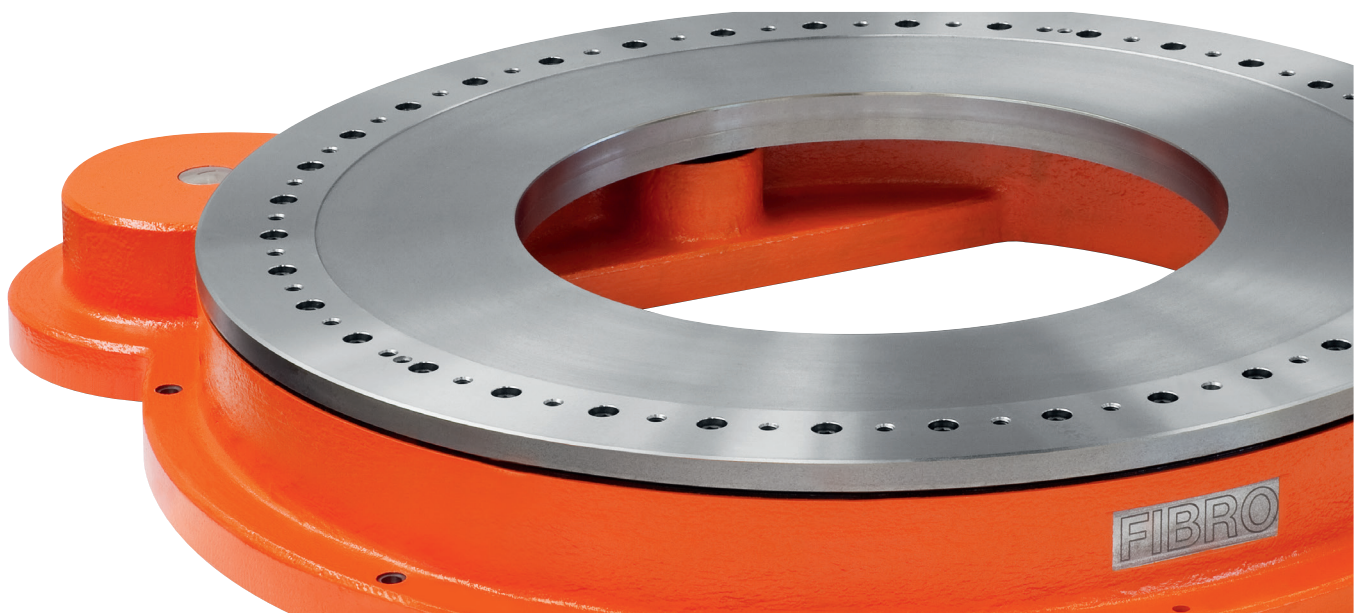

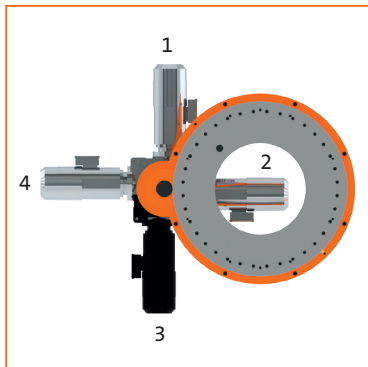

FIBROMAT AT.0800
Drive arrangement 10, 20, 30, 40

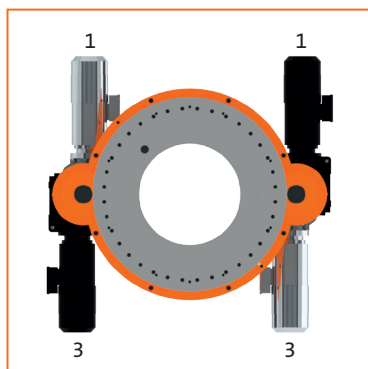

FIBROMAT AT.0800
Drive arrangement 11, 13, 31, 33

Dimensions of FIBROMAT® AT.0800

(Drive arrangement 180° with one drive; for other drive arrangements, diagrams or CAD data are available)

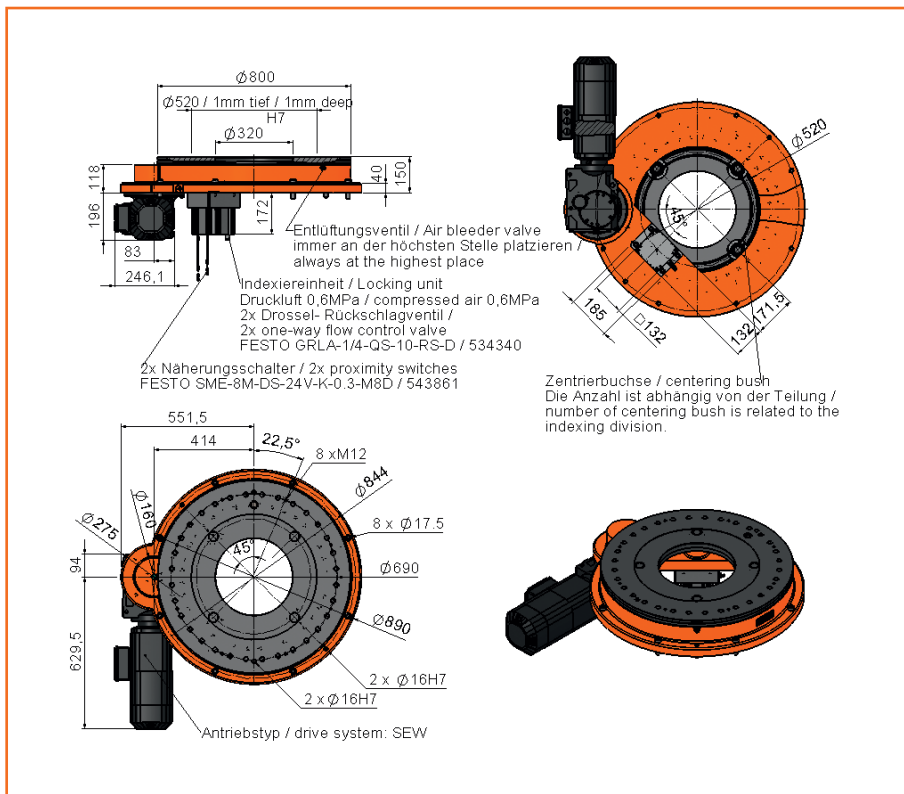

Technical data for FIBROMAT® AT.0800

Coding

AT.0800

Table top dimension	Ø 800 mm			
Drive motor	1 drive without motor	Gearbox prepared for motor according to customer	.10	②
	1 drive with motor	SEW asynchronous servo gear motor KF57/R DRL 90L4BE2/TF/AS7W/Z	.11	
	1 drive with motor	SIEMENS Motor 1FK7100-5AF71-1EH0	.12	
	1 drive with motor	Special motor	.19	
	2 drives without motor	Gearboxes prepared for motors according to customer	.20	
	2 drives with motor	SEW asynchronous servo gear motor KF57/R DRL 90L4BE2/TF/AS7W/Z	.21	
	2 drives with motor	SIEMENS Motor 1FK7100-5AF71-1EH0	.22	
	2 drives with motor	Special motor	.29	
Drive arrangement	See pictures above		.XX	
	Special design		.99	
Divisions Any, maximum 16	Without indexing unit		.00	④
	With indexing unit for division XX, symmetrical arrangement		.XX	
	Special division		.99	
Centre hole	Ø 320 mm		.0	⑤
	Extended by 200 mm (not combinable with standard indexing unit)		.1	
	Special design		.9	
Measuring system	Measuring system on motor		.0	⑥
	With additional direct measuring system (mounted in standard centre hole)		.1	
	With measuring system in special design		.9	
Direction of rotation	Any			
Mounting position	Any, standard table top: horizontal (Please state other mounting positions when ordering)			
Indexing and repeat accuracy	Indexing accuracy	Repeat accuracy		
No indexing, one drive	± 315"	± 160"		
No indexing, two drives	± 65"	± 35"		
With indexing, one drive	± 28"	± 14"		
With two drives, with measuring system	± 10"	± 5"		

Technical data for FIBROMAT® AT.0800

Maximum axial runout of the table top	0.05 mm		
Maximum runout of the centre hole	0.05 mm		
Weight	FIBROMAT AT.0800	350 kg	
	Gear motor	53 kg	
	Indexing unit	25 kg	

Indexing times for FIBROMAT® AT.0800

AT.0800 with one drive								
45°	t _s in s	2.7	2.4	2.1	1.9	1.7	1.3	1.0
	J in kgm ²	8,000	6,000	4,000	3,000	2,000	1,000	500
90°	t _s in s	3.8	3.4	3.1	2.9	2.5	1.9	1.6
	J in kgm ²	8,000	6,000	4,000	3,000	2,000	1,000	500
180°	t _s in s	5.7	5.3	4.8	4.2	3.6	3.1	2.8
	J in kgm ²	8,000	6,000	4,000	3,000	2,000	1,000	500

AT.0800 with two drives								
45°	t _s in s	1.8	1.6	1.5	1.4	1.1	0.9	0.8
	J in kgm ²	8,000	6,000	4,000	3,000	2,000	1,000	500
90°	t _s in s	2.8	2.6	2.2	1.9	1.7	1.5	1.3
	J in kgm ²	8,000	6,000	4,000	3,000	2,000	1,000	500
180°	t _s in s	4.6	4.5	3.4	3.1	2.9	2.6	2.5
	J in kgm ²	8,000	6,000	4,000	3,000	2,000	1,000	500





The specified switching times do not include: Regulation time of 0.1 sec, indexing time of 0.3 sec. Further angels and indexing times can be calculated for you.

Load data for FIBROMAT® AT.0800

Perm. transport load on table top horizontal	10.000 kg
Perm. superstructure diameter	4.500 mm
Perm. force vertically on rotating table top	141.000 N
Perm. radial force on the rotating table top	56.000 N
Perm. tilting moment on rotating table top	35.000 Nm
Perm. tangential moment on table top (dynamic)	6.500 Nm

We would be pleased to provide a calculation of combined load data for your specific application.

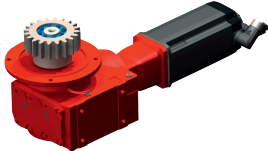
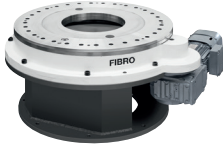
Additional options for FIBROMAT® AT.0800

Drive unit Asynchronous motor (standard)		Indexing unit	
Drive unit Synchronous servomotor		Machine stands Height: 397 mm	
Drive inverter		Additional table top	

CAD data, technical data and planning documentation can be downloaded from www.fibro.com.

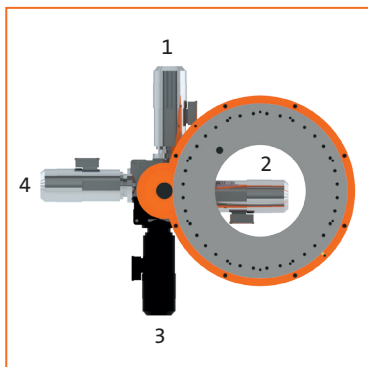

FIBROMAT AT.1000
Drive arrangement 10, 20, 30, 40

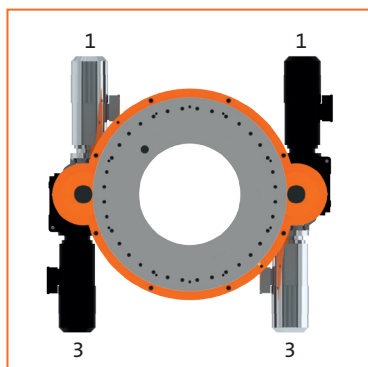

FIBROMAT AT.1000
Drive arrangement 11, 13, 31, 33

Dimensions of FIBROMAT® AT.1000

(Drive arrangement 180° with one drive; for other drive arrangements, diagrams or CAD data are available)

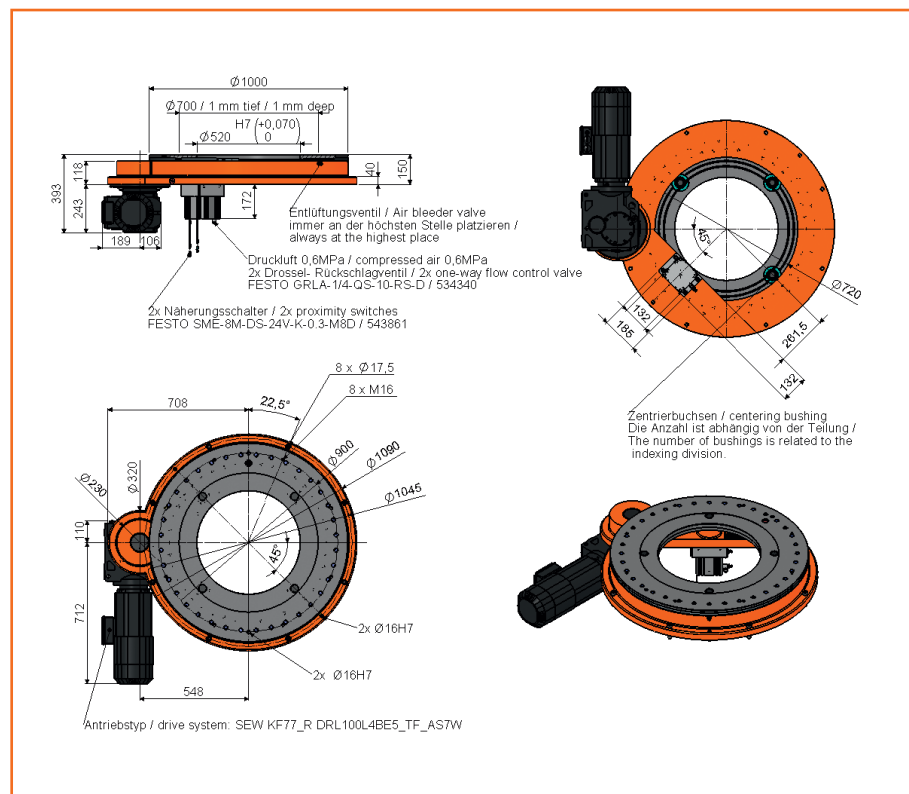

Technical data for FIBROMAT® AT.1000

Coding

AT.1000

Table top dimension	Ø 1,000 mm		
Drive motor	1 drive without motor 1 drive with motor 1 drive with motor 1 drive with motor 2 drives without motor 2 drives with motor 2 drives with motor 2 drives with motor	Gearbox prepared for motor according to customer SEW asynchronous servo gear motor KF77/R DRL 100L4BE5/TF/AS7W/Z SIEMENS Motor 1FK7103-5AF71-1EH0 Special motor Gearboxes prepared for motors according to customer SEW asynchronous servo gear motor KF77/R DRL 100L4BE5/TF/AS7W/Z SIEMENS Motor 1FK7103-5AF71-1EH0 Special motor	.10 .11 .12 .19 .20 .21 .22 .29
Drive arrangement	See pictures above Special design		.XX .99
Divisions Any, maximum 22	Without indexing unit With indexing unit for division XX, symmetrical arrangement Special division		.00 .XX .99
Centre hole	Ø 520 mm Extended by 200 mm (not combinable with standard indexing unit) Special design		.0 .1 .9
Measuring system	Measuring system on motor With additional direct measuring system (mounted in standard centre hole) With measuring system in special design		.0 .1 .9
Direction of rotation	Any		
Mounting position	Any, standard table top: horizontal (Please state other mounting positions when ordering)		
Indexing and repeat accuracy	Indexing accuracy	Repeat accuracy	
No indexing, one drive	± 290"	± 145"	
No indexing, two drives	± 50"	± 25"	
With indexing, one drive	± 20"	± 10"	
With two drives, with measuring system	± 10"	± 5"	

Technical data for FIBROMAT® AT.1000

Maximum axial runout of the table top	0.05 mm		
Maximum runout of the centre hole	0.05 mm		
Weight	FIBROMAT AT.1000	470 kg	
	Gear motor	95 kg	
	Indexing unit	25 kg	

Indexing times for FIBROMAT® AT.1000

AT.1000 with one drive									
45°	t _s in s	2.8	2.5	2.2	2.0	1.7	1.4	1.1	0.9
	J in kgm ²	16,000	12,000	8,000	6,000	4,000	2,000	1,000	500
90°	t _s in s	4.0	3.6	3.1	2.9	2.6	2.0	1.6	1.5
	J in kgm ²	16,000	12,000	8,000	6,000	4,000	2,000	1,000	500
180°	t _s in s	5.9	5.5	5.0	4.8	3.8	3.1	2.8	2.7
	J in kgm ²	16,000	12,000	8,000	6,000	4,000	2,000	1,000	500

AT.1000 with two drives									
45°	t _s in s	1.9	1.7	1.5	1.4	1.2	0.9	0.8	0.7
	J in kgm ²	16,000	12,000	8,000	6,000	4,000	2,000	1,000	500
90°	t _s in s	2.9	2.7	2.5	2.4	1.8	1.5	1.4	1.3
	J in kgm ²	16,000	12,000	8,000	6,000	4,000	2,000	1,000	500
180°	t _s in s	4.8	4.6	4.4	4.3	3.0	2.7	2.5	2.5
	J in kgm ²	16,000	12,000	8,000	6,000	4,000	2,000	1,000	500



The specified switching times do not include: Regulation time of 0.1 sec, indexing time of 0.3 sec. Further angles and indexing times can be calculated for you.

Load data for FIBROMAT® AT.1000

Perm. transport load on table top horizontal	12,000 kg
Perm. superstructure diameter	6,000 mm
Perm. force vertically on rotating table top	155,000 N
Perm. radial force on the rotating table top	64,000 N
Perm. tilting moment on rotating table top	50,000 Nm
Perm. tangential moment on table top (dynamic)	9,400 Nm

We would be pleased to provide a calculation of combined load data for your specific application.

Additional options for FIBROMAT® AT.1000

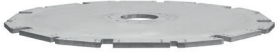
Drive unit Asynchronous motor (standard)		Indexing unit	
Drive unit Synchronous servomotor		Machine stands Height: 457 mm	
Drive inverter		Additional table top	

CAD data, technical data and planning documentation can be downloaded from www.fibro.com.

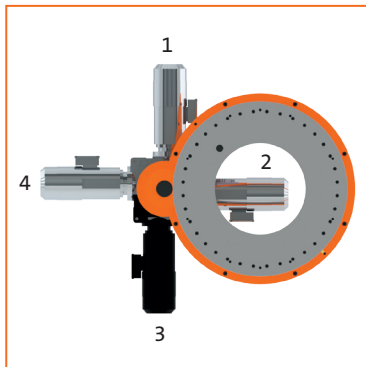

FIBROMAT AT.1250
Drive arrangement 10, 20, 30, 40

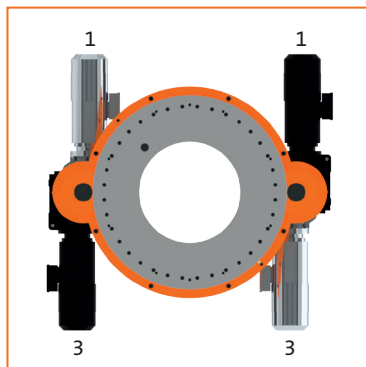

FIBROMAT AT.1250
Drive arrangement 11, 13, 31, 33

Dimensions of FIBROMAT® AT.1250

(Drive arrangement 180° with one drive; for other drive arrangements, diagrams or CAD data are available)

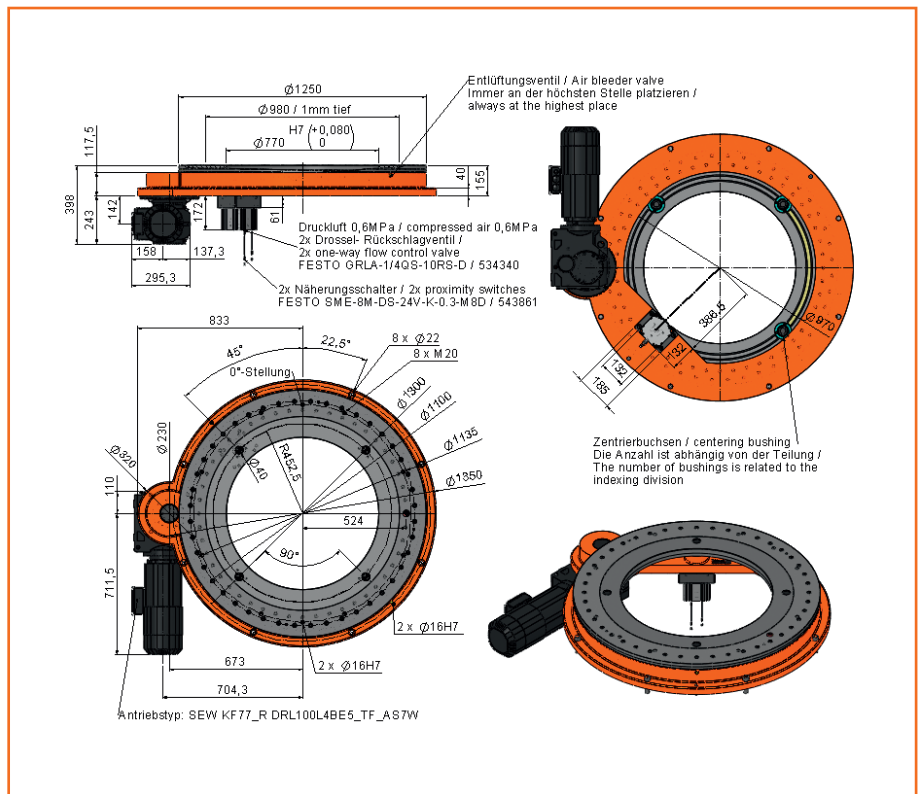

Technical data for FIBROMAT® AT.1250

Coding

AT.1250 - - - - -

Table top dimension	Ø 1,250 mm		
Drive motor	1 drive without motor 1 drive with motor 1 drive with motor 1 drive with motor 2 drives without motor 2 drives with motor 2 drives with motor 2 drives with motor	Gearbox prepared for motor according to customer SEW asynchronous servo gear motor KF77/R DRL 132S4BE5/TF/AS7W/Z SIEMENS Motor 1FK7105-5AF71-1EH0 Special motor Gearboxes prepared for motors according to customer SEW asynchronous servo gear motor KF77/R DRL 132S4BE5/TF/AS7W/Z SIEMENS Motor 1FK7105-5AF71-1EH0 Special motor	.10 .11 .12 .19 .20 .21 .22 .29
Drive arrangement	See pictures above Special design		.XX .99
Divisions Any, maximum 30	Without indexing unit With indexing unit for division XX, symmetrical arrangement Special division		.00 .XX .99
Centre hole	Ø 770 mm Extended by 200 mm (not combinable with standard indexing unit) Special design		.0 .1 .9
Measuring system	Measuring system on motor With additional direct measuring system (mounted in standard centre hole) With measuring system in special design		.0 .1 .9
Direction of rotation	Any		
Mounting position	Any, standard table top: horizontal (Please state other mounting positions when ordering)		
Indexing and repeat accuracy	Indexing accuracy	Repeat accuracy	
No indexing, one drive	± 290"	± 145"	
No indexing, two drives	± 60"	± 30"	
With indexing, one drive	± 15"	± 8"	
With two drives, with measuring system	± 10"	± 5"	

Technical data for FIBROMAT® AT.1250

Maximum axial runout of the table top	0.07 mm		
Maximum runout of the centre hole	0.07 mm		
Weight	FIBROMAT AT.1250	635 kg	
	Gear motor	112 kg	
	Indexing unit	25 kg	

Indexing times for FIBROMAT® AT.1250

AT.1250 with one drive										
45°	t _s in s	3.7	3.4	3.1	2.8	2.5	2.3	2.0	1.7	1.3
	J in kgm ²	35,000	30,000	25,000	20,000	16,000	12,000	8,000	4,000	2,000
90°	t _s in s	5.2	4.8	4.4	3.9	3.6	3.3	3.0	2.3	1.9
	J in kgm ²	35,000	30,000	25,000	20,000	16,000	12,000	8,000	4,000	2,000
180°	t _s in s	7.3	6.9	6.4	5.9	5.6	5.3	4.4	3.5	3.0
	J in kgm ²	35,000	30,000	25,000	20,000	16,000	12,000	8,000	4,000	2,000

AT.1250 with two drives										
45°	t _s in s	2.5	2.3	2.1	1.9	1.7	1.6	1.5	1.1	0.9
	J in kgm ²	35,000	30,000	25,000	20,000	16,000	12,000	8,000	4,000	2,000
90°	t _s in s	3.5	3.3	3.1	2.9	2.7	2.6	2.1	1.7	1.5
	J in kgm ²	35,000	30,000	25,000	20,000	16,000	12,000	8,000	4,000	2,000
180°	t _s in s	5.5	5.3	5.1	4.9	4.7	4.6	3.2	2.8	2.6
	J in kgm ²	35,000	30,000	25,000	20,000	16,000	12,000	8,000	4,000	2,000





The specified switching times do not include: Regulation time of 0.1 sec, indexing time of 0.3 sec.
Further angels and indexing times can be calculated for you.

Load data for FIBROMAT® AT.1250

Perm. transport load on table top horizontal	15,000 kg
Perm. superstructure diameter	7,500 mm
Perm. force vertically on rotating table top	172,000 N
Perm. radial force on the rotating table top	80,000 N
Perm. tilting moment on rotating table top	72,000 Nm
Perm. tangential moment on table top (dynamic)	12,900 Nm

We would be pleased to provide a calculation of combined load data for your specific application.

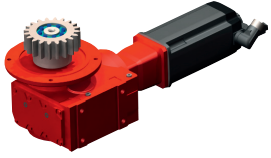
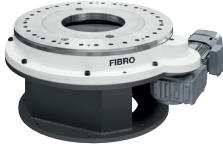
Additional options for FIBROMAT® AT.1250

Drive unit Asynchronous motor (standard)		Indexing unit	
Drive unit Synchronous servomotor		Machine stands Height: 457 mm	
Drive inverter		Additional table top	

CAD data, technical data and planning documentation can be downloaded from www.fibro.com.

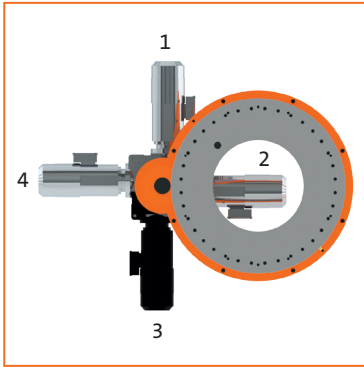

FIBROMAT AT.1600
Antriebsausrichtung 10, 20, 30, 40

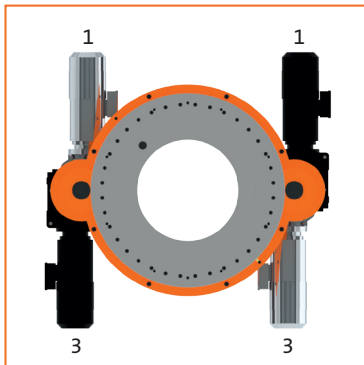

FIBROMAT AT.1600
Drive arrangement 11, 13, 31, 33

Dimensions of FIBROMAT® AT.1600

(Drive arrangement 180° with one drive; for other drive arrangements, diagrams or CAD data are available)

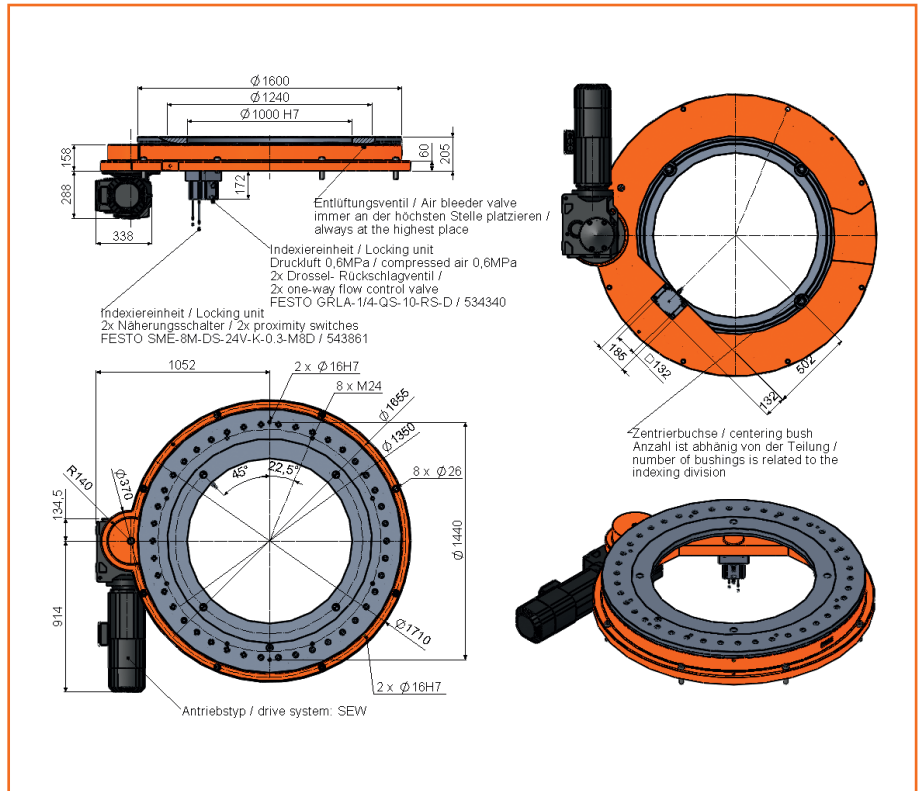

Technical data for FIBROMAT® AT.1600

Coding

AT.1600

Table top dimension	Ø 1,600 mm		
Drive motor	1 drive without motor 1 drive with motor 1 drive with motor 1 drive with motor 2 drives without motor 2 drives with motor 2 drives with motor 2 drives with motor	Gearbox prepared for motor according to customer SEW asynchronous servo gear motor KF87/R DRL 132MC4BE5/TF/AS7W/Z SIEMENS Motor 1FK7105-5AF71-1EH0 Special motor Gearboxes prepared for motors according to customer SEW asynchronous servo gear motor KF87/R DRL 132MC4BE5/TF/AS7W/Z SIEMENS Motor 1FK7105-5AF71-1EH0 Special motor	.10 .11 .12 .19 .20 .21 .22 .29
Drive arrangement	See pictures above Special design		.XX .99
Divisions Any, maximum 38	Without indexing unit With indexing unit for division XX, symmetrical arrangement Special division		.00 .XX .99
Centre hole	Ø 1,000 mm Extended by 200 mm (not combinable with standard indexing unit) Special design		.0 .1 .9
Measuring system	Measuring system on motor With additional direct measuring system (mounted in standard centre hole) With measuring system in special design		.0 .1 .9
Direction of rotation	Any		
Mounting position	Any, standard table top: horizontal (Please state other mounting positions when ordering)		
Indexing and repeat accuracy	Indexing accuracy	Repeat accuracy	
No indexing, one drive	± 285"	± 145"	
No indexing, two drives	± 60"	± 30"	
With indexing, one drive	± 20"	± 10"	
With two drives, with measuring system	± 10"	± 5"	

Technical data for FIBROMAT® AT.1600

Maximum axial runout of the table top	0.1 mm		
Maximum runout of the centre hole	0.1 mm		
Weight	FIBROMAT AT.1600	1,400 kg	
	Gear motor	170 kg	
	Indexing unit	25 kg	

Indexing times for FIBROMAT® AT.1600

AT.1600 with one drive										
45°	t _s in s	4.7	4.0	3.3	2.8	2.5	2.3	2.2	2.0	1.7
	J in kgm ²	100,000	75,000	50,000	35,000	25,000	20,000	16,000	12,000	8,000
90°	t _s in s	6.6	5.7	4.7	4.0	3.8	3.4	3.1	2.8	2.5
	J in kgm ²	100,000	75,000	50,000	35,000	25,000	20,000	16,000	12,000	8,000
180°	t _s in s	9.3	8.2	7.0	6.1	5.4	5.0	4.7	4.4	4.1
	J in kgm ²	100,000	75,000	50,000	35,000	25,000	20,000	16,000	12,000	8,000

AT.1600 with two drives										
45°	t _s in s	3.1	2.7	2.2	1.9	1.8	1.6	1.5	1.3	1.2
	J in kgm ²	100,000	75,000	50,000	35,000	25,000	20,000	16,000	12,000	8,000
90°	t _s in s	4.4	3.9	3.4	2.9	2.6	2.4	2.3	2.2	2.0
	J in kgm ²	100,000	75,000	50,000	35,000	25,000	20,000	16,000	12,000	8,000
180°	t _s in s	6.8	6.3	5.7	4.5	4.2	4.0	3.9	3.8	3.7
	J in kgm ²	100,000	75,000	50,000	35,000	25,000	20,000	16,000	12,000	8,000





The specified switching times do not include: Regulation time of 0.1 sec, indexing time of 0.3 sec. Further angles and indexing times can be calculated for you.

Load data for FIBROMAT® AT.1600

Perm. transport load on table top horizontal	25,000 kg
Perm. superstructure diameter	9,500 mm
Perm. force vertically on rotating table top	260,000 N
Perm. radial force on the rotating table top	220,000 N
Perm. tilting moment on rotating table top	135,000 Nm
Perm. tangential moment on table top (dynamic)	16,300 Nm

We would be pleased to provide a calculation of combined load data for your specific application.

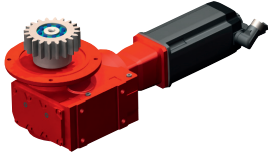
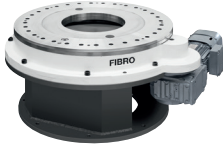
Additional options for FIBROMAT® AT.1600

Drive unit Asynchronous motor (standard)		Indexing unit	
Drive unit Synchronous servomotor		Machine stands Height: 557 mm	
Drive inverter		Additional table top	

CAD data, technical data and planning documentation can be downloaded from www.fibro.com.