

10

to Zen

- 1) Adequate Knowledge of Business
- 2) New Product Development
- 3) Bigger Basket Offering
- 4) In House Quality Check
- 5) Timely Delivery
- 6) Our Services
- 7) Optimal Solution
- 8) Commitment
- 9) Trust & Reliability
- 10) Good Business Practices

10 Years in business with unchanged value...

“No Compromise”

Kitten has been pioneers in Marketing & Manufacturing of Industrial Filters, Clean-Room Products & Sterilization Packaging Material and since then there has been no looking back. Even being a mid size company our world class innovative products and highly efficient customer services make us pioneers of this respective market. We take Pride in our ability to propose tailored and abrupt solutions for the challenges coming from our valued clients -

"LET IT BE AN EXTREMELY LARGE INVENTORY OF THE HIGHEST QUALITY PRODUCTS OR TIGHT DEADLINES OF DAYS AND SOMETIMES EVEN HOURS".

Kitten being an ISO 9001:2008 certified company, assures that there clients gets the quality & delivery of their products just as per there requirements.

Our Customers are from different industries such as Pharmaceutical, Biotech, Alcoholic & Non-Alcoholic Beverages, Chemicals, Paint & Ink, Automotive & Fluid Processing Industries. They all hold a very special space for us hence we endeavor not only to meet but exceeds there expectations. We want to go beyond our clients expectations and provide them more quality, standard and efficiency while dealing with Kitten!

“Filtration”



Filter Pad For Liquid Filtration

The Carlson XE range of products comprises a comprehensive series of high performance filter sheets designed to meet the needs

All filter sheets within the XE range are formulated with several important benefits in mind:

All XE filter sheets incorporate an advanced blend of selected and processed bleached cellulose fibres combined with non-hazardous filter-aids and approved resins to produce filter media with superior filtration capabilities in conjunction with excellent wet and dry handling characteristics.

All the raw materials used in the manufacture of XE products are carefully selected and monitored to ensure their compatibility with beverages and food products.

All XE products are made to the same carefully controlled thickness specification so that the different grades can be used in the same filter press configuration and seal thickness.

Edge leakage is reduced to a minimum because of the special XE filter sheet formulation and processing conditions.

XE filtration sheets are widely used in the filtration of products where they give outstanding clarity and stability combined with long sheet life and integrity.

Typical applications of the XE range include spirits, wines, beers and lagers where long life, sterility, stability and clarity are essential. Similarly, XE products have found wide acceptance in the filtration of syrups for soft drinks, gelatines and cosmetics, plus a diverse spread of chemical and pharmaceutical intermediates and final products.

Typical particle retention values of XE range (um)			
GRADE	MIN	RANGE	MAX
XE1700H	0.1	0.2	0.3
XE1200H	0.2	0.2	0.4
XE900H	0.4	0.1	0.5
XE675H	0.4	0.2	0.6
XE400H	0.5	0.3	0.8
XE280H	0.5	1	1.5
XE200H	1.5	1	2.5
XE150H	3	4	7
XE90H	4	5	9
XE80H	5	5	10
XE70H	5	7	12
XE50H	6	9	15
XE20H	8	12	20
XE10H	9	13	22
Xe5	10.5	14.5	25

Physical Data					
Test properties units	Basic weight g/m ²	Thickness mm	% Ash Content % weight (g)	Flow rate	
				litres/min/m ² @ 1 bar	litres/min/m ² 0.3 bar
Xe1700H	1450	3.80	50	24	
XE1200H	1400	3.80	50	47	
XE900H	1375	3.75	50	60	
XE675H	1375	3.75	50	80	
XE400H	1325	3.75	44	150	
XE280H	1290	3.75	44	193	
XE200H	1265	3.75	42	270	
XE150H	1235	3.75	42	373	
XE90H	1190	3.75	42	448	
XE70H	1140	3.75	38	600	
XE50H	1150	3.75	38	685	
XE20H	1050	3.75	25	1098	
XE10H	1040	3.75	18	1308	
Xe5	790	3.60	1		2280

• The following figures are nominal values, for specifications contact your representative.

Instructions for correct use

When inserting into the filter press handle the filter sheets with care to eliminate distortion or abrasion. Never use a damaged filter sheet.

Insertion of depth filter sheets

To ensure correct use place the smooth side of the filter sheet against the filtration plate (i.e downstream). The rough side of the filter sheet faces the liquid to be filtered (i.e upstream).

Filter preparation

Prior to the first filtration it is recommended where possible to pre-rinse the closed filter with approximately 50 litres of water per m² at 1.25 times the flow rate. During pre-rinsing check for leakage, re-tighten to eliminate if necessary.

Sterilisation

Carlson range of XE filter sheets may be sterilised with saturated steam or hot water. The pressed filter pack has to be loosened slightly to ensure that the steam has entirely sterilised the system. Final pressure should only be applied to the filter package once the entire filter has cooled down.

Sterilisation with steam:

Steam quality: Steam has to be free of foreign particles and impurities
 Temperature: max 1340c (saturated steam)
 Duration: 20minutes

Sterilisation with hot water:

Water quality: The water should be softened and be free of impurities
 Temperature: 80-850c
 Duration: 20 minutes

Sheet flushing

The Carlson range of XE filter sheets can be forward and back washed using softened water to extend the life and reduce the costs of filtration. This is, however, very much dependent upon the application and filtration conditions.

Safety and disposal

Used under the correct conditions the Carlson range of XE filter sheets have no known negative effects and can be disposed of through normal route, observing local and official regulations. Consult MSDS for further information.

Forms of supply

XE range of filter sheets are available in all customary sizes, hygienically shrink-wrapped and packed in cardboard boxes. Special formats are available on request.

Remarks

All Carlson Filtration Ltd filter sheets are manufactured in accordance with BfR recommendation XXXV1/1 (regulations regarding paper and board designed for contact with foodstuffs) and EC Regulation No 1935/2004 (materials and articles intended to come into contact with food).

All our products are made according to the rules of Quality Management System EN ISO 9001:2008

We provide information and advice to the best of our knowledge. This information cannot be binding in every case on account of the variety of applications, work methods and operating conditions. We, therefore, cannot assume liability for improper use.



Pharmaceutical Grade Carbon Filter Pad

For pharmaceutical and fine chemical markets

Carlson offer a standard range of 3 Carlcarb carbon grades aimed primarily at pharmaceutical and fine chemical applications. Other bespoke carbon grades are available, subject to volume. All grades are low pyrogen content, are high carbon content (60%) and standard weight (1300gsm).

Carlcarb ICN has excellent micro and meso porosity and is widely used in pharmaceuticals for endotoxin reduction and decolourisation. The carbon is of high purity, with high activation levels and with very low trace metal content. It is also USP compliant.

Carlcarb MCN is a high performance carbon with a broad range of adsorption but is particularly good for macro porosity and removal of large colour molecules, associated with decolourisation of vitamins, antibiotics and proteins. High purity level.

Carlcarb PCN is a cost effective carbon used in general pharmaceutical applications. Offers a high level of activation across the macro, meso and micro pore sizes. Excellent colour adsorption plus broad adsorption range. Low ion levels.

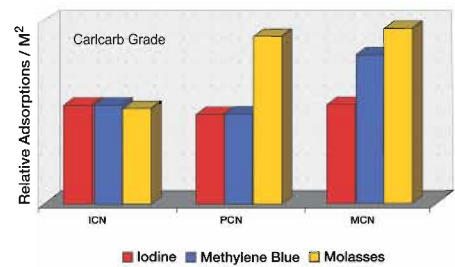

	12" Module		16" Module		40 cm Sheet		60 cm Sheet		Application	Structural Pore		Endotoxin EU/ml
	Kg PAC	M²	Kg PAC	M²	Kg PAC	M²	Kg PAC	M²		Size		
ICN	1.4	1.8	2.8	3.6	0.12	0.16	0.27	0.36	Decolorisation, Endotoxin reduction	Medium	Small	<0.1
PCN	1.4	1.8	2.8	3.6	0.12	0.16	0.27	0.36	Decolorisation,	Medium	Large	<0.1
MCN	1.4	1.8	2.8	3.6	0.12	0.16	0.27	0.36	Decolorisation, Vitamins, Antibiotics, Proteins	Medium	Large	<0.1

NB PAC-Powdered Activated Carbon



For beverage, chemical and general applications

Carlson offer the Carcarb "A" range of carbon media in 3 forms to suit different applications:

Carcarb AN Standard carbon content (46%) and standard weight (1300 gsm)

Carcarb ALN Standard carbon content (46%) and lightweight (1080 gsm)

Carcarb ACN High carbon content (60%) and standard weight (1300 gsm)

Carcarb QCN High carbon content (60%) and standard weight (1300 gsm)

Carcarb "A" carbon is our standard grade with a good broad adsorption range, from micro to macro pore size. For general non pharmaceutical use. Good colour removal and high activation level. Used widely in beverage, sugar, chemical and miscellaneous applications

Carcarb QCN High carbon content (60%) and standard weight (1300 gsm)

Carcarb QCN is a higher adsorption, higher performance grade for similar markets and applications. With high 60% carbon content, low ion content and a higher adsorption capacity carbon, QCN is a premium performance version of the Carcarb "ACN" grade.

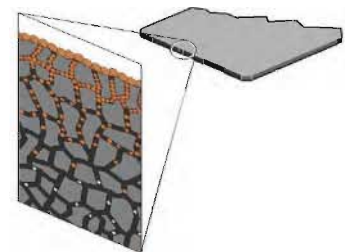
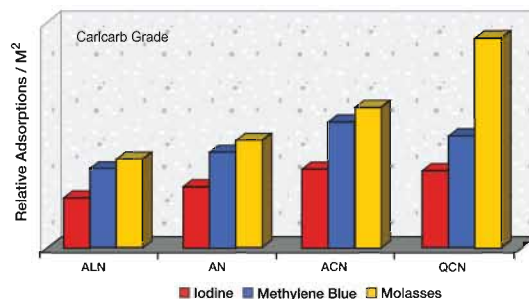

Section through a typical Carlson Carcarb sheet

	12" Module		16" Module		40 cm Sheet		60 cm Sheet		Application	Structural Pore	
	Kg PAC	M ²	Kg PAC	M ²	Kg PAC	M ²	Kg PAC	M ²		Size	
AN	1.08	1.8	2.16	3.6	0.1	0.16	0.23	0.36	Decolorisation, Deodourisation	Medium	Large
ALN	0.9	1.8	1.8	3.6	0.08	0.16	0.18	0.36	Decolorisation, Deodourisation	Medium	Large
ACN	1.4	1.8	2.8	3.6	0.12	0.16	0.27	0.36	Decolorisation, Deodourisation	Medium	Large
QCN	1.4	1.8	2.8	3.6	0.12	0.16	0.27	0.36	Decolorisation, Deodourisation	Medium	Large

NB PAC-Powdered Activated Carbon

Filter Pad For Liquid Filtration (zeta potential)

SC Grade Depth Filter Sheets

«Low Ion» or «Low Ion and Low Pyrogen» For pharmaceutical and other high purity applications

Characteristics

SC range of depth filter sheets represent an approved and established filtration technology for solid liquid separation.

The three dimensional medium assures superior retention capacity for solid particles at a high flow rate.

The pore sizes can be fine enough to retain bacteria and thus produce a sterile liquid (logarithmic retention of bacteria up to LRV 8). The dirt holding capacity of an SC range depth filter sheet can be up to 4 kg per m².

In the filtration process, solid particles are slowed down and eventually retained by the tortuous path inside the filter sheet and by electrokinetical interactions («zeta potential»). Through this unique mechanism, a high capacity (long lifetime of filter until plugging) can be achieved.

SC and SCP grades are highly pure depth filter media. SC grades have a very low ion release and SCP has both, low ion and a low pyrogen release.

All materials are FDA approved.

Applications

The broad variety of available porosities allow for their use in a wide range of applications. Porosity grades are available from coarse over fine to germ reducing and germ removing filtration («sterile filtration»).

Examples of industries:

- API (Active pharmaceutical ingredients)
- Biotech (pharmaceuticals)
- Beverage (spirits)
- Enzymes
- Herbal or other natural extracts
- Pharmaceutical intermediates
- Solvents

Sheet sizes

SC grade sheets are available in various sizes and shapes up to 2m width: square, rectangular, round, with/without holes, foldover, etc.

Available grades

Standard version	High capacity version*	Retention rate [µm]	
SC 6 (P)		35 – 15	Coarse filtration
SC 9 (P)		30 – 10	
SC 15 (P)		20 – 8.0	
SC 20 (P)	SC 21H (P)	15 – 6.0	Clarifying filtration
SC 30 (P)	SC 31H (P)	12 – 5.0	
SC 40 (P)	SC 41H (P)	9.0 – 4.0	
SC 50 (P)		6.0 – 3.0	
SC 70 (P)	SC 71H (P)	3.0 – 1.5	Fine filtration
SC 100 (P)	SC 101H (P)	1.5 – 0.6	Germ reducing filtration
SC ST 110 (P)		0.8 – 0.5	Sterile filtration
SC ST 130 (P)		0.6 – 0.4	
SC ST 140 (P)		0.4 – 0.2	
SC ST 150 (P)		0.2 – 0.04	

Handling

Depth filter sheets are used in a sheet filter, such as the NOVOX® series. The sheets need to be wetted in place and pre-flushed with 50 L/m². A pressure difference between in and outlet assures constant flow.

The sheets are exhausted when the differential pressure exceeds a certain value (1.0 – 2.5 bar), depending on porosity and application).

Sterilisation conditions

The sheets can be sterilized with hot water (85°C) or inline steam (125°C).

logarithmic bacteria retention value (LRV) LRV of germ reducing or germ removing sheets:

Type	Test germ	Load	LRV
SC 101 H (P)	Germ reducing (reducing the no. of germs in filtrate)		
SC ST 110 (P)	Serratia marcescens	1.0 X 107/cm2	>6
SC ST 130 (P)	Serratia marcescens	1.0 X 108/cm2	>7
SC ST 140 (P)	Serratia marcescens	1.0 X 109/cm2	>8
SC ST 150 (P)	Brevundimonas diminuta	1.0 x 109/cm2	>8
Test germs:	Serratia marcescens, ATCC 14756 Brevundimonas diminuta, ATCC 19146		

Pyrogen release (for SC P» series, only)
Due to a special manufacturing process the SC P series has a reduced specified endotoxin release < 0.125 EU/ml.

Chemical resistance (filter sheets)

Substance	Concentration [%]	Resistance	
		T = 20° C	T = 80° C
NaOH	1	r	r
NaOH	2	r	lr
HCl	5	r	lr
HNO ₃	5	r	lr
H ₂ SO ₄	10	r	lr
Acetic Acid	Conc.	r	r
Citric Acid	10	r	r
Peracetic Acid	0.1	r	r
Butanol	80	r	r
Ethanol	80	r	r

r = resistant; lr = limited resistant
For the complete list please refer to our special documentation

Quality assurance

We assure the best quality control according to international standards:

- ISO 9001 (Quality management)
- ISO 14001 (Environmental management)
- HACCP
- FDA drug master file: # 16418

External tests of filter sheets were performed and certified according to

- CFR requirements by the NAMSA

Polyamidoamine is used as a wet strength agent in its filter sheets. The ISEGA Institute for food analysis in Aschaffenburg (Germany) performed a test for extractable MCPD and DCP. The filter sheets extracts were below the detection limit of the approved standard method for DCP and MCPD. All sheets are kosher for passover.

Validation support

For validation support of pharmaceutical applications there is a comprehensive validation guide available, containing all current certificates, analysis results (FDA, CFR, USP), declarations (GMO, TSE).

EU safety data sheets

EU safety data sheets for all types of PURAFIX® sheets can be downloaded from the FILTROX website.

Hardcopies are available upon request

Material

Purified and bleached cellulose, natural inorganic filter aids, polyamidoamine (< 3%).

Free of plastic fibers and formaldehyde. The filter sheets are free of GMO and common allergens.

Disposal

Uncontaminated sheets can be recycled like paper, composted or disposed with the domestic waste. Contaminated sheets must be disposed according to the contamination.

Storage life and conditions

Sheets should be stored in their original packaging in an odorless, dry and ventilated environment. We recommend use of the filter sheets within 36 months after purchase.

Options

In applications of enzymes with high cellulase activity «Cellulase Resistant» filter sheets (Pat. pend.) are available.

SC 15 or SC 71H are also available in a version with extra high zeta potential: SC 15S and SC 71S. The additional positive charge leads to a higher adsorption of negatively charged particles, such as dye molecules.

For intermediates or pre filtration with lower demands on ion or pyrogen release we recommend our food approved standard XE grade of filter sheets.

Diatomaceous earth

Sheets with an ash content > 1 contain diatomaceous earth (DE / «Kieselguhr») or perlite as an inorganic filter aid.

Filter Modules

TECHNICAL INFORMATION

The lenticular filter modules are of either 12” (300mm) or 16” (400mm) diameter, to match the appropriate housing. Each module is normally made up of 16 cells. Each cell consists of 2 discs of filter media formed around an internal, all polypropylene skeleton. The outer edges of the media are sealed with an injection moulded polypropylene strip. The complete filter module is assembled from up to 16 cells packed together with a special internal polypropylene structure allowing the formation of a completely sealed, pre compressed unit. These modules can then be used in a single or multiple housing, stacked end to end up to 4 high. End seal is via either flat gasket or double o-ring bayonet fitting.

Specification for 12” lenticular module

Module Diameter	: 288mm +/- 2mm
Quantity of filter cells	: 16 (standard) : 9 : 2
Nominal filter area	: 1.8m ² : 1.0m ² : 0.2m ²

Specification for 16” lenticular module

Module diameter	: 401mm +/- 2mm
Quantity of filter cells	: 16 (standard) : 9 : 2
Nominal filter area	: 3.6m ² : 2.0m ² : 0.4m ²

Specifications applicable to both 16” and 12”

Compressed module height	
Including 2 flat gaskets	: 272 +/- 2mm : 165 +/- 3mm : 52 +/- 3mm
Matrix, end cap, sealing ring	: Material :- Natural Polypropylene.
Outside sealing of filter discs	: Complete and regular injected polypropylene outer seal of filter discs.
Materials	: Fixing straps : 304 stainless steel (standard) or hastalloy or polypropylene.
Flat gaskets	: Silicone (standard), nitrile, PTFE, Viton or EPDM.
O-ring seal	: Silicone (standard), EPDM or Viton.
Scrims	: Non woven polyester

Lenticular Module Flow Diagram

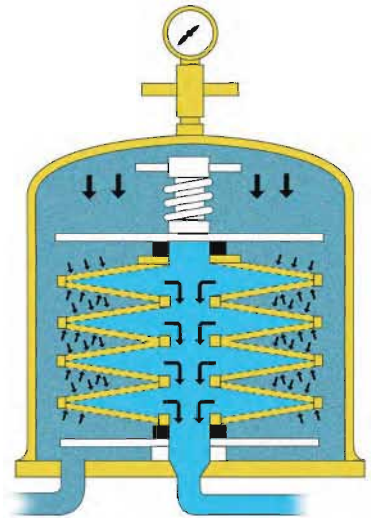

RANGE AVAILABLE

The range of depth filter media available in lenticular format includes:

- W2 filter aid support grades for DE filtration or coarse filtration.
- Medium grades ie XE5 through to XE50 for coarse filtration.
- Clarification and polishing grades ie XE70 through to XE400.
- Sterilising grades to remove bacteria and some viruses ie XE675 through to XE1700.
- Low pyrogen, low ion and low calcium grades for use in Pharmaceutical and other applications.
- Specialist grades ie Carlcab Proc3 Activated Carbon grades

Range Indicator

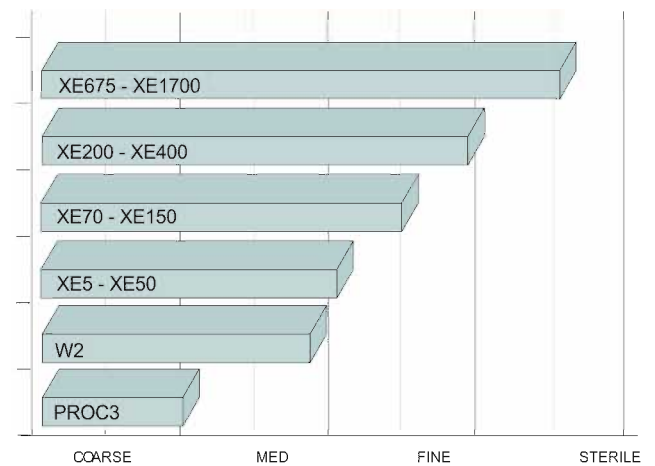

For more information on the grades of media please see the appropriate product leaflets.

Filter Paper For Liquid Filtration

AHLSTROM

The wide availability of filtering paper of the Ahlstrom series allows you to have an optimal response to the demands of customers who seek a quality product with defined characteristics of the filtration and maximum reliability.

Ahlstrom Filter Paper range from 150 g / m² to 700 g / m².

All papers are produced using FDA approved pulp high quality resins that make the filter a product of absolute assurance.

To demonstrate the versatility of this product and its quality, we can boast among consumers with the most important companies in the oil sector, pharmaceutical and chemical industries.

We can supply all sizes that customers require circle, square and rectangular formats with any creasing. All formats can with round or square holes.

Following Grade are Available:

C-200, C-350, C-510, C-650

Applications

- Pharmaceuticals
- Drugs
- Food Processing
- Beverages
- Chemicals
- Cosmetics
- For charcoal
- Activated carbon
- Catalyst filtration



PolyPliT Pleated PP Membrane Filter Cartridge



Advantages :

- Designed for general filtration purposes of both liquid & gas.
- Filtering material is double layered polypropylene membrane and internal support is given by PP shell.
- Thermally welded without any adhesive or medium break off.
- Excellent chemical compatibility, high flow rate, low pressure difference, long life, low price, wide filtration.
- Precise and can be used in different place.
- Resist to sanitization of high pressure and steam.
- Excellent dirt holding capacity.

Quality Assurance :

- ISO 9001:2000 certified company.
- Pharmaceutical grade material.
- Pharmaceutical grade workshops, (according to GMP criterion).
- Strick test before packing.

Materials Of Construction :

- Membrane : PP.
- Core : Polypropylene.
- O-ring/Gasket : Silicone/Viton/TEF/EPDM.

Applications :

- Medical Industries : Filtration of organic solvent and compressed air and other gases.
- Electronic Industry : Pre-filtration in returning water filtration system.
- Food & Beverage Industries : Filtration of wine, mineral water and purified water.
- Others : Liquid filtration of organic solvent, ink, galvanization fluid, metal cutting fluid and sensitization anticorrosion

Technical Data :

- Effective filtration area (10") : $\geq 0.6 \text{ m}^2$.
- Normal working temperature: $\leq 55^\circ\text{C}/131^\circ\text{F}$.
- Max. working temperature : 80°C ($P \leq 1 \text{ bar}$).
- Max. differential pressure : 4.2 bar.
- PH value : 1-13.
- Sterilization method : Autoclaving ($121+2^\circ\text{C}$) within 30 min.
- Water flow rate with different pressure : See the chart.

Water Flow Rate With Different Pressure (10")

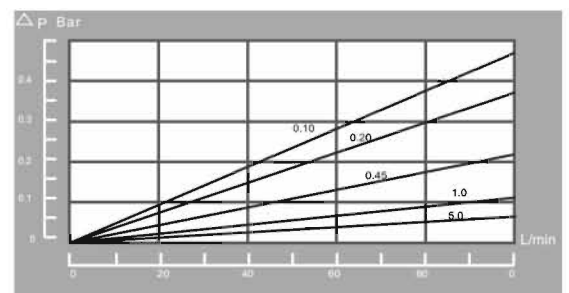

Specifications :

- Pore size(μm) : 0.10, 0.20, 0.45, 1.0, 3.0, 5.0, 10, 20, 40.
- Length (inch) : 5, 10, 20, 30, 40.
- Outer Diameter(mm) : 68.
- Endcaps : DOE, SOE (code2, code3, code7, code8).

Ordering Information :

PPR	Length"	Filtration Efficiency	End Cap	Seal Material
↓	↓	↓	↓	↓
Removal Rating				
0.10	5 = 5" Long	N = Normal	S1 = DOE	S=Silicone
0.20	10 = 10" Long	A = Absolute	S3 = Code - 7	E=EPDM*
1.0	20 = 20" Long		S7 = Code - 3	V=Viton*
3.0	30 = 30" Long		S8 = Code - 8	P=PFA/Viton*
5.0	40 = 40" Long			
10				
20				
30				

Filter Cartridge - PSN



Advantages :

- Made up of silicone free material as 100% polypropylene media.
- Providing multiple filtration zone, which produces gradient pore structure.
- The outer section captures larger particles while innermost section efficiently & consistent remove smaller particles.
- Excellent Chemical resistance.
- High dirt holding capacity.
- High flow rate & low differential pressure.
- FDA complied polypropylene material.

Applications:

- Electronic Industry : Etching solution, electroplating.
- Chemical Industry : Adhesive, solvent, surfactant, chemical liquid.
- Food and Beverage : Wine, potable water, beer, soft drink, brewery, edible oils.
- General process industry : Pre-filtration for DI and RO system, process water.

Materials Of Construction :

- Filtration Media : 100% melt blown polypropylene micro fiber.
- Inner core and adapters : Nil. • O-rings & gaskets : Nil.



Pressure Drop VS. Water Flow Rate

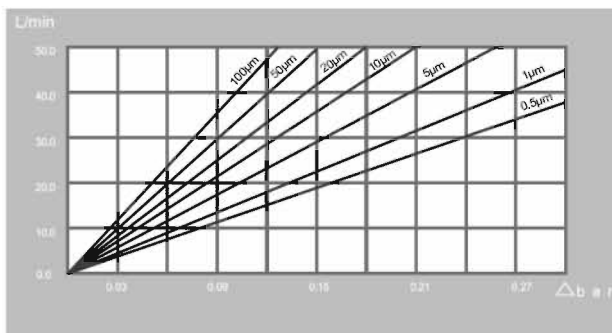

Technical Data:

- Maximum Differential Pressure : 2.1 bar at 60°C.
4.2 bar at 30°C.
- Maximum operating temperature: PP core – 176°F/80°C.

Specifications:

- Length : 10,20,30,40.
- ID : 28, 30mm.
- Outer Diameter(mm) : 62.
- Effective filtration Area : 0.05 m² per 10 inch.

Ordering Information :

PSN	Length"	Filtration Efficiency	End Cap	Seal Material
↓	↓	↓	↓	↓
Removal Rating				
0.5	10 = 10" Long	A = Absolute	S1 = DOE	S=Silicone
1	20 = 20" Long	N= Nominal	S3 = Code - 7	E=EPDM*
5	30 = 30" Long			V=Viton*
10	40 = 40" Long			P=PFA/Viton*
20				
50				
100				

Filter Cartridge - PTN



Advantages :

- Polyvin is a non-woven melt blown multi layer type filter cartridge.
- Featuring a graded density matrix of all polypropylene fiber.
- No media migration.
- Thermally bonded without the use of surfactants, binders & adhesives.
- Long life span process & superior pre filtration.

Applications :

- Chemical Industry : Paint, ink, magnetic paint, oil resin, solvent, enzyme, plating chemicals, adhesive, resin, photographic chemical, metal working.
- Food and Beverage : Wine, potable water, beer, soft drink, brewery, sugar liquid, industry edible oils.
- General process industry : PDP, chemical liquid, water for print – circulation – board, prefiltration for RO, slurry UF, pure water, safety filter or ion exchange machine.

Materials Of Construction :

- Filtration media : Graded density spun polypropylene.
- Inner core & Out Cage : Polypropylene, reinforced Polypropylene by Talc.
- O-ring/Gasket : Silicone, EPDM, Viton, TEF & Foamed polyethylene.



Pressure Drop VS. Water Flow Rate

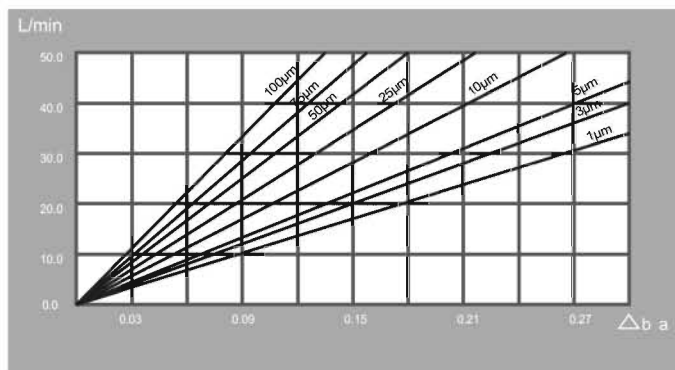

Technical Data :

- Effective filtration area : 0.05 m² per 10 inch.
- Max. differential pressure : 2.1 bar at 60°C.
4.2 bar at 30°C.
- Max. operating temperature : PP core 176°F/ 80°C.

Specifications :

- Length (inch) : 5, 10, 20, 30, 40.
- ID (mm) : 28, 30.
- Outer Diameter (mm) : 62.

Ordering Information :

<u>PTN</u>	<u>Length"</u>	<u>Filtration Efficiency</u>	<u>End Cap</u>	<u>Seal Material</u>
↓ <u>Removal Rating</u>				
0.5	5 = 5" Long	N = Normal	S1 = DOE	S=Silicone
1	10 = 10" Long	A = Absolute	S3 = Code - 7	E=EPDM*
2	20 = 20" Long			V=Viton*
3	30 = 30" Long			P=PFA/Viton*
5	40 = 40" Long			
10				
25				
30				
50				
100				

Filter Cartridge - PSG



Advantages :

- Polypropylene string or cotton string or Glass fiber reeled on the polypropylene core or S S Core.
- This is designed for applications where reliable and consisted depth filtration is required.
- High flow rates with excellent ability to retain dirt.
- Good chemical compatibility and low price.
- Suitable for high temperature and pressure process.
- Easy installation and replacement.
- Low maintenance cost.
- Available in wide range of materials and micron ratings.

Quality Assurance :

- ISO 9001:2000 certified company.
- Pharmaceutical grade material.*

Applications :

- General Process Industry - Prefiltration for water purification.
- Food & Beverage Industry - Coarse filtration for all kinds of beverage and wine like edible oil, coco butter, sugar, saccharin, starch syrup, soft drink,beer.
- Chemical Industry - Acid, base, organic solvent, plating solution, magnetic coating, polyester resin.
- Oil & Gas Industry - Amine, glycol, lubricating oil.



Materials Of Construction :

- String : Polypropylene / Cotton / Glass fiber.
- Core : Polypropylene / SS.

Technical Data

- Effective filtration area (10") : >0.04m².
- Max. differential pressure : 4.2 bar. at 25°C
- pH value : 1-13.
- Max working temperature :
 - Polypropylene - 80°C
 - Cotton - 150°C
 - Glass Fiber - 300°C

Specifications

- Pore size(µm) : 1-100
- Outer Diameter(mm) : 63
- Length (inch) : 10,20,30,40.
- Type : DOR

Ordering Information :

PSG	Micron	Length"	Filtration Efficiency	End Cap
↓	↓	↓	↓	↓
Cartridge	01 = 1 Micron	10=10" Long	N = Nominal	1=Double open end.
PSG = Polypropylene	03 = 3 Micron	20=20" Long		
GFP = Glass Fiber	05 = 5 Micron	30=30" Long		
CFP = Cotton Fiber	10 = 10 Micron	40=40" Long		
	25 = 25 Micron			
	50 = 50 Micron			
	100 = 100 Micron			

Filter Cartridge - PTT



Advantages:

- Made up of super pure Titanium powder (99.6%).
- High aperture rate, excellent structure and good mechanical performance.
- Can work under extreme high or low temperature.
- Good chemical stability & can resist corrosion of acid and alkali, anti-oxidation.
- Can purify or separate all kinds of solid, liquid, air and gas.

Quality Assurance:

- ISO 9001:2000 certified company.
- Pharmaceutical grade material.
- Pharmaceutical grade workshops (according to GMP criterion).
- Strick test before packing.

Applications :

- Medical industry : Decarbonization filtration for transfusion, injection and oral medicine fluid, safety filtration before the end filtration in dilution process.
- Chemical industry : Filtration of dirt and pigment; filtration for returning water in oil fields.
- Sewage processing industry : Filtration for Ozone after antiseptis & ozone exposure filtration.
- Food & Beverage industry : Clarification for liquor, beer, mineral water, vegetable oil, soy sauce etc.

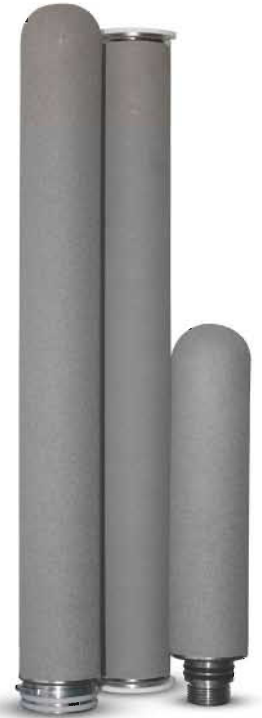

Materials Of Construction :

- Filtration Media : Titanium.
- Core : Nil.
- O-ring/Gasket : EPDM, VITON.

Technical Data:

- Effective filtration area (10") : $\geq 0.4m^2$.
- Pressure resistance : 5 - 15 bar.
- Max. working temperature : 280°C / 536°F (wet).
- Max. working pressure : ≥ 6 bar ($\leq 25^\circ C$).
- Max. differential pressure : 4.2 bar.
- pH value : 1-14.
- Sterilization method : Nil.

Specifications:

- Pore size (μm) : 1 - 120.
- Length (inch) : 10, 20, 30, 40.
- Endcaps : Nil.

Ordering Information :

<u>PTT</u>	<u>Length"</u>	<u>Filtration Efficiency</u>	<u>End Cap</u>	<u>Seal Material</u>
↓	↓	↓	↓	↓
<u>Removal Rating</u> 1-120	10 = 10" Long 20 = 20" Long 30 = 30" Long 40 = 40" Long	N = Normal A = Absolute	S1 = DOE S3 = Code - 7 S7 = 1" BSP	S=Silicone E=EPDM* V=Viton* P=PFA/Viton* T = Teflon

Filter Cartridge - STP



Main Features:

- Pleated Stainless Steel mesh to maximizethe filtration area
- Suitable for high temperature and pressure conditions
- Can be backwashed, long life
- High ability to corrosion resistant
- Better for filtering the liquid with high viscosity of food and beverage



Table 1: Specifications & Technical data

Materials:	Filter Media:	Ss304 / SS316 mesh
	Downstream & Upstream Drainage:	Ss304 / SS316 mesh
	Outer Cage:	NIL
	Core:	Ss304 / SS316
	O-ring/Gasket:	Silicone/EPDM/Viton/Nitrile/ Teflon (encaptulated)
Specifications:	Pore size (um):	1um, 3um, 5um, 10um,20um,25um
	Outer Diameter(OD):	60mm or 80mm
	Nomina Length (inch. 10"=250mm)	10, 20, 30, 40
Technical data:	Effective filtration area (10"):	≥0.4 M2
	Max. working temperature:	200 °C / 392°F
	Max. differential pressure:	6.0 bar at 25°C
	PH value:	1-14

Table 2: ORDER INFORMATION

PRODUCT	MICRON	ADAPTER	LENGTH	O-RING / Gasket
STP	3um-300	A- DOE	10"-1	Silicone-S; N-Nitrile EPDM- E ; T-Teflon (Encaptulated) Viton- V
	5um-500	BSP- BSP Threaded	20"-2	
	10um-1000	BF-222/ FLAT SEAL	30"-3	
	20um-2000	CF-226/FLAT SEAL	40"-4	
			Other-7	For example: Micon:3um; Length:10" ADAPTER: 226/FLAT O-ring: Silicone. Selection Code is: STP300CF1S

DUST COLLECTION BAGS



Kitten manufactures a vast variety of woven & non-woven filter media bags for dust collections.

Standard Temperature bags

These bags are fabricated in various medias like Polyester (1400), Polypropylene (900), Acrylic (1300), used in various types of industries for different types of applications.

High Temperature bags

These bags are fabricated in various medias like Fiberglass (2600), Nomex (2100), Ryton (1900), PTFE (2400), used in various types of industries for different types of applications.

Finished Treatment available

1. Water & Oil repellent – anti adhesive
2. Antiacid Treatment
3. Antistatic Treatment with SS fibre, SS wire, carbon fibre as per customer requirements.
4. PTFE impregnation, membrane lamination & Coating



Filter Bag - Polypropylene/Polyester



The FiltroUNO™ PO filter bag is one of the most versatile and popular bags on the market. Made from a noninserted polypropylene felt with a glazed surface finish, the standard bag incorporates the welded seam design. The F Neck ring provides hermetic sealing, preventing steel ring bypass problems. And the welded seam eliminates unfiltered liquid bypass occurring due to needle holes. The PE filter bag is made from non-inserted polyester, and can be ordered with the PE Neck ring.



These bags come in a variety of sizes and ring seals* to suit your vessel requirements.

FILTER DIMENSIONS		MAXIMUM FLOW RATE <small>For water @ 30°C</small>
Size 1	7 Ø x 16.5 in	18 m ³ /h - 300 LPM
Size 2	7 Ø x 32 in	34 m ³ /h - 566 LPM
Size 3	4 Ø x 8 in	5.7 m ³ /h - 95 LPM
Size 4	4 Ø x 14 in	11.4 m ³ /h - 190 LPM
Maximum operating temperature		93°C (PO), 135°C (PE)
Suggested maximum differential pressure		1.72 bar

Ordering Information (Example :F1PO1S2FW)

<u>F1</u>	<u>PO</u>	<u>Micron</u>	<u>Size</u>	<u>Collar Type</u>	<u>Seam</u>
FiltroUNO™	Media PO = Polypropylene PE = Polyester	01 = 1 Micron 03 = 3 Micron 05 = 5 Micron 10 = 10 Micron 25 = 25 Micron 50 = 50 Micron 100 = 100 Micron 200 = 200 Micron	1 2 3 4	SS: Stainless Steel S: Carbon Steel F: F type (Polypropylene) G: G type (Polypropylene) N: Non collar U: Band NY: Nylon	W: Welded

Filter Bag - Extended Life



FiltroUNO™ Extended Life felt filter bag series is designed to provide longer service life resulting in reduced operation costs and process down time. The unique blend of fibres in extended life media offers 2 to 5 times the dirt holding capacity of traditional felt media. The 100% thermally bonded construction and PolyformSEAL™ top retainer provide excellent sealing characteristics in most industry standard filter bag housings.

- POXL: Polypropylene extended life felt in 1, 5, 10, 25, 50, and 100 micron.
- PEXL: Polyester extended life felt in 1, 5, 10, 25, 50, and 100 micron.

Material of Construction

- **Filter media:** (POXL) = Polypropylene extended life felt
(PEXL) = Polyester extended life felt
- **Retainer Options:** PP Ring



FILTER DIMENSIONS		MAXIMUM FLOW RATE <small>For water @ 30°C</small>
Size 1	7 Ø x 16.5 in	18 m ³ /h - 300 LPM
Size 2	7 Ø x 32 in	34 m ³ /h - 566 LPM
Maximum operating temperature POXL		93°C
Maximum operating temperature PEXL		135°C
Suggested maximum differential pressure		1.72 bar

Ordering Information (Example : PEXL 1 P2PW)

<u>PO</u>	<u>Micron</u>	<u>Cover</u>	<u>Size</u>	<u>End Cap</u>	<u>Options</u>
↓ Media	↓	↓	↓	↓	↓
POXL = Polypropylene Extended Life PEXL = Polyester Extended Life	01 = 1 Micron 05 = 5 Micron 10 = 10 Micron 25 = 25 Micron 50 = 50 Micron 100 = 100 Micron	P: Plain, no cover	1=7"x16.5" 2=7"x32"	P = Polypropylene Ring K = Polyester Ring	W: Welded

Filter Bag - NMO (Nylon)



The FiltroUNO™ Monofilament Nylon Filter Bag (NMO) is constructed using a woven fabric. Each thread is a single filament, providing excellent strength with no fiber migration. The fabric is designed with evenly spaced holes. The monofilament yarn used in the fabric is extremely abrasion resistant, resistant to a broad range of chemicals, unaffected by metal fatigue or corrosion, has no loose fibers and boasts high tensile strength.



FILTER DIMENSIONS		MAXIMUM FLOW RATE <small>For water @ 30°C</small>
Size 1	7 Ø x 16.5 in	18 m3/h - 300 LPM
Size 2	7 Ø x 32 in	34 m3/h - 566 LPM
Size 3	4 Ø x 8 in	5.7 m3/h - 95 LPM
Size 4	4 Ø x 14 in	11.4 m3/h - 190 LPM
Maximum operating temperature PEM		135°C
Maximum operating temperature NMO		135°C
Maximum operating temperature PPMO		93°C
Suggested maximum differential pressure		1.72 bar

Ordering Information (Example : F1NMO 150 S2FA)

<u>F1</u> ↓ <u>Micron</u> ↓ FiltroUNO™	<u>NMO</u> ↓ Nylon	<u>1</u> ↓ <u>Micron</u> ↓	<u>Size</u> ↓	<u>Collar Type</u> ↓	<u>Seam</u> ↓ A = Automotive
		01 = 1 Micron	1	SS: Stainless Steel	
		05 = 5 Micron	2	S: Carbon Steel	
		10 = 10 Micron	3	F: F type (Polypropylene)	
		25 = 25 Micron	4	G: G type (Polypropylene)	
		50 = 50 Micron		N: Non collar	
		75 = 75 Micron		U: Band	
		100 = 100 Micron		NY: Nylon	
		150 = 150 Micron			
		200 = 200 Micron			
		400 = 400 Micron			
		500 = 500 Micron			
		600 = 600 Micron			

Filter Bag - POMF (Oil Absorption)



The FiltroUNO™ POMF filter bag made from 100% polypropylene melt-blown microfiber provides great oil absorbency.

The FiltroUNO™ POMF filter featured with high chemical resistance can absorb unwanted oil.

Features and Benefits :

- High flow rate, high loading capacity
- Effective oil absorbency
- Multilayered construction, high surface area
- Customized service available
- 100% polypropylene, FDA listed material.



FILTER DIMENSIONS		MAXIMUM FLOW RATE <small>For water @ 30°C</small>
Size 1	7 Ø x 16 in	245LPM*
Size 2	7 Ø x 32 in	476LPM*
Maximum operating temperature		80°C
Recommended Operating Pressure Drop		≤1 .5 kg/cm2
Suggested maximum differential pressure		2 bar

Ordering Information (Example :F1POMFCAS2FW)

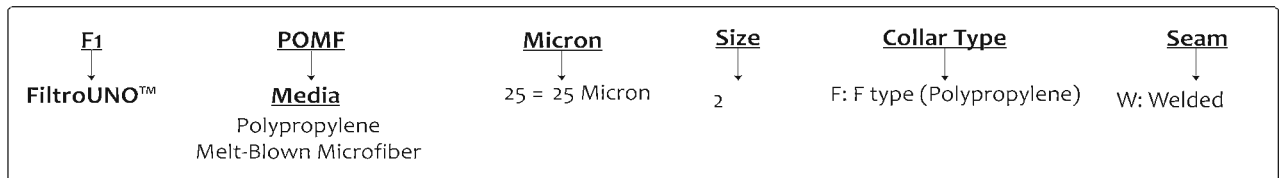

Filtration Efficiency

Material	Model	Filtration Efficiency (µm)					ΔP(bar) SIZE 2 @ 10M ³ /H
		>60%	>90%	>95%	>99%	>99.9%	
Polypropylene	F1POMF5	1	2	3	5	10	0.09
	F1POMF10	2	3	5	10	25	0.22
	F1POMF25	5	10	15	25	50	0.05
	F1POMF50	10	25	35	50	75	0.04
	F1POMF75	15	25	50	75	100	0.03
	F1POMF100	25	50	75	100	150	0.02

Initial Pressure Drop

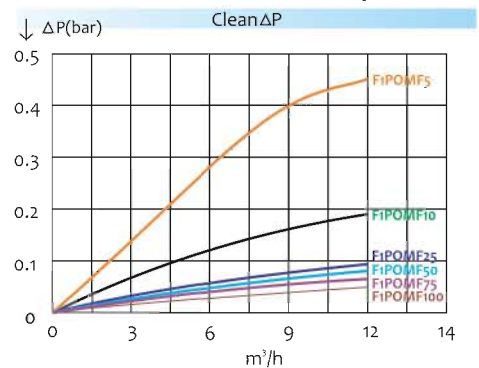

Non-woven PP/PE Filter Cloth



We confirm that the Polypropylene and/or Polyester Fibres used to manufacture the FDA compliance with:
 FDA Title 21 CFR177:1520(Polypropylene) / FDA Title 21 CFR177.1630 (Polyester)
 for food contact that necessary precautions are taken this manner

Unique Specialized Nonwoven Textile Products and Solutions:
 Specializing in the making of needle-punched nonwoven fabrics for technical applications with processes of bed coverings to manufacture nonwoven felt for clothing industries.

Advantages:

High-performance nonwoven filtration media that exceed industry standards

Optimal performance: Strict quality control at every stage of production ensures consistency and uniform technical features over the entire surface of the filtration media

First-grade fiber from reliable & certified sources. FDA-approved fibers for the food & beverage and pharmaceutical sectors are also available

Flexibility: Available with or without reinforcement or finishing

Filter media that last 1.6 to 4 times longer than standard products. Optimized design enables better particle retention while maintaining filtration efficiency. FDA and EEC approved grades available.

Applications

- Food and beverage processing
- Petrochemicals
- Edible oil processing
- Paints
- Water treatment
- Brewery filtration
- And more

Product Identification

Media	Description	Type	Surface Weigh Mean (6.9cm disc) g/m ²		Air Permeability cfm		Thickness (Manual Gauge 20z) mm		Method
			Min.	Max.	Min.	Max.	Min.	Max.	
Polypropylene	PPFC 001	Needlepunch Nonwoven	500.000	580.000	8.000	22.000	2.300	2.900	ASTM-D3776
	PPFC 005		300.000	350.000	50.000	80.000	1.600	2.400	ASTM-D737
Polyester	PEFC 005		300.000	350.000	55.000	85.000	1.500	2.100	ASTM-D5729

Round Filter Press (Sparkler)



Kitten has been actively involved in the manufacturing & marketing of filtration system more than Eight years. We are now adding one more product “**Filter Press Round Plate**” with “o” hold up.

REVERSE FLOW ZERO HOLD UP TYPE :
Here the direction of flow of liquid is exactly opposite to the flow in standard filter i.e. the impure to be filtered enters the filter from the bottom into the center channel & goes to the top of each plate. The clear filtrate flows out from openings on side of plates to the shell & then to the outlet. This flow ensure almost 100% filtration of the liquid which is not so with the standard flow type.

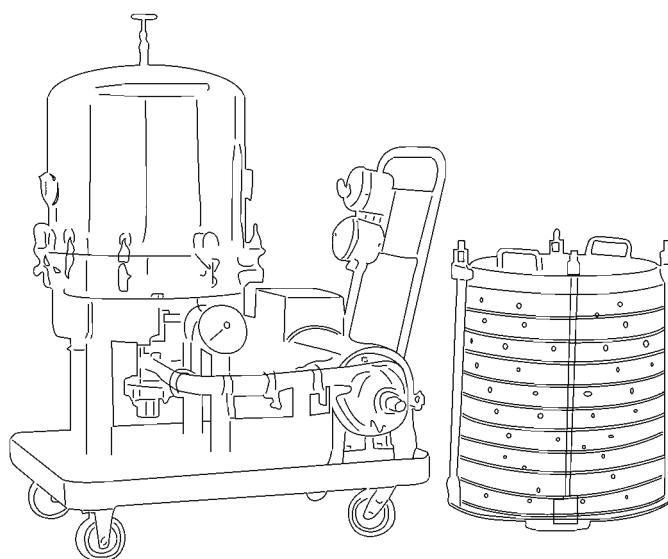

Model	Dia. Of Plates / Plate Depth	No. Of Plates	Filtering Area m ²	Cake holding Cap. (Ltrs.)		Flow* Rate/ Hrs for water
				25 mm	38 mm	
FPR 8	8 x 25 mm	6	0.223	4.9		600
		8	0.287	6.3		800
FPR 14	14 x 25 mm Or 18 x 38 mm	8	0.88	19.54	29.70	1500
		10	1.075	24.42	37.13	1700
		12	1.270	29.31	44.55	1900
FPR 18	18 x 25 mm Or 18 x 38 mm	10	1.79	25 mm	38 mm	4000
		12	2.11	40.63	61.76	4600
		15	2.60	48.76	74.11	5500
		24	4.06	60.95	92.647	8200
				97.52	148.235	

- Material of construction S S 304 Or S S 316
- Gasket option - Silicone or EPDM Or Viton & PTFE
- Trolley mounted with Castor wheel
- We do not supply pressure pump
- Connection option - 1” Or 2”
- Connection type - Nozzle type, Flange type or user specific

Cartridge / Bag Filter Housings



Cartridge Filter Housing

Cartridge filter system offers wide range of flow capacities & contaminant holding capacities. Cartridge filter housing diameters can accommodate around 1 to 500 cartridges. Cartridge filters are normally used as polishing filter in almost all process industries. Cartridge filter is constructed of filter housing, filter cartridges, tube sheet, positive sealing arrangement for cartridge depending upon type of cartridge & choice of end connections. Positive sealing arrangement for cartridge filter assures no particle migration or fiber migration, even after high differential pressures.

Bag Filter Housing

Bag filter system is designed for optimum filtration performance. Its range provides filtration solution for a broad variety of fluid applications in the process industry. They are particularly useful for filtering large volumes of high viscosity liquids. Bag filter is constructed of filter housing, filter bags, internal cage to support bags, positive sealing arrangement, & choice of end connections. The internal support ensures bags will not burst as high differential pressures build up during operation.

Material of construction

- » SS316L
- » SS 316
- » SS 304
- » Super Duplex, Duplex Stainless steel
- » CARBON STEEL (ALL GRADE)
- » MILD STEEL
- » ALLOY METALS
- » POLYPROPYLENE
- » LEAD LINING on Any Metal
- » RUBBER LINING on Any Metal
- » PTFE LINING on Any Metal

Applications

- » Processing Chemicals
- » Petroleum Derivatives
- » Coolants
- » Cutting Oils
- » Cleaning Fluids
- » Vegetable Oils
- » Edible Oils
- » Polymers
- » Paints
- » Inks
- » Resins
- » Varnishes
- » Lacquers
- » Pharmaceuticals
- » Sugar Syrup
- » Plastics



Cartridge / Bag Filter Housings - PP



Standard Filter Housings

- Ideal for a wide range of applications, including residential, commercial and industrial
- Available in 10" and 20" lengths
- Optional pressure-relief/bleed button on inlet side of cap
- Thick walls for increased strength
- Leak-proof sealing with top-seated Buna-n o-ring
- Available with clear or opaque sumps

Standard filter housings are manufactured of a durable polypropylene or clear FDA-compliant Styrene-Acrylonitrile (SAN). All are equipped with 3/4", 1" or 1.5" BSP inlet & outlet ports. Standard filter housings are available in both 10" and 20" lengths and will accommodate a wide range of 2 1/2" to 4" diameter cartridges. The reinforced polypropylene cap and offers an optional pressure-relief button on the inlet side to relieve pressure inside the housing when changing filter cartridges.

Reinforced polypropylene housings have excellent chemical resistance and are ideal for many residential, commercial and industrial applications. Clear sumps offer onsite examination of the cartridge.

Opaque Standard Filter Housings are molded from rugged reinforced polypropylene. They offer outstanding chemical compatibility and are ideal for use in a variety of low-flow applications. These applications include under-sink and countertop residential filtration, pre-and post-reverse osmosis filtration, recreational vehicle filtration, food service and humidifying systems.

Clear Standard Filter Housings offer on-site examination of flow, performance, and cartridge life. They are also ideal for a variety of applications.



Housing Specifications

10" and 20" Standard Housings

Model No.	Description	Max Press. (psi)	Inlet/Outlet Size
BFH-1034-BL	Blue 10" Housing	125	3/4"
CFH-1034-CL	Clear 10" Housing	125	3/4"
BFH-1034-CL	Blue 20" Housing	125	3/4"
CFH-1034-CL	Clear 20" Housing	125	3/4"

10" and 20" Big Housings

Model No.	Description	Max Press. (psi)	Inlet/Outlet Size
BFH-1034-BB	10" Housing	125	3/4"
BFH-101-BB	10" Housing	125	1"
BFH-115-BB	10" Housing	125	1.5"
BFH-201-BB	20" Housing	125	1"
BFH-2015-BB	20" Housing	125	1.5"

Bag Filter Housings

Model No.	Description	Max Press. (psi)	Inlet/Outlet Size
BFH-101-FB	10" Housing	100	1"
BFH-1015-FB	10" Housing	100	1.5"
BFH-201-FB	20" Housing	90	1"
BFH-2015-FB	20" Housing	90	1.5"



An ISO 9001 Registered Company 

Kitten Enterprises Pvt Ltd.

W 407, Rabale MIDC, Near "Hamara Mahanagar" Press, Navi Mumbai 400701, India.

Tel: +91-22-27646464, 9930359882 | Fax: +91-22-27649299

Email: bparekh@kitten.co.in | Web: www.kitten.co.in