

STAR COUPLINGS

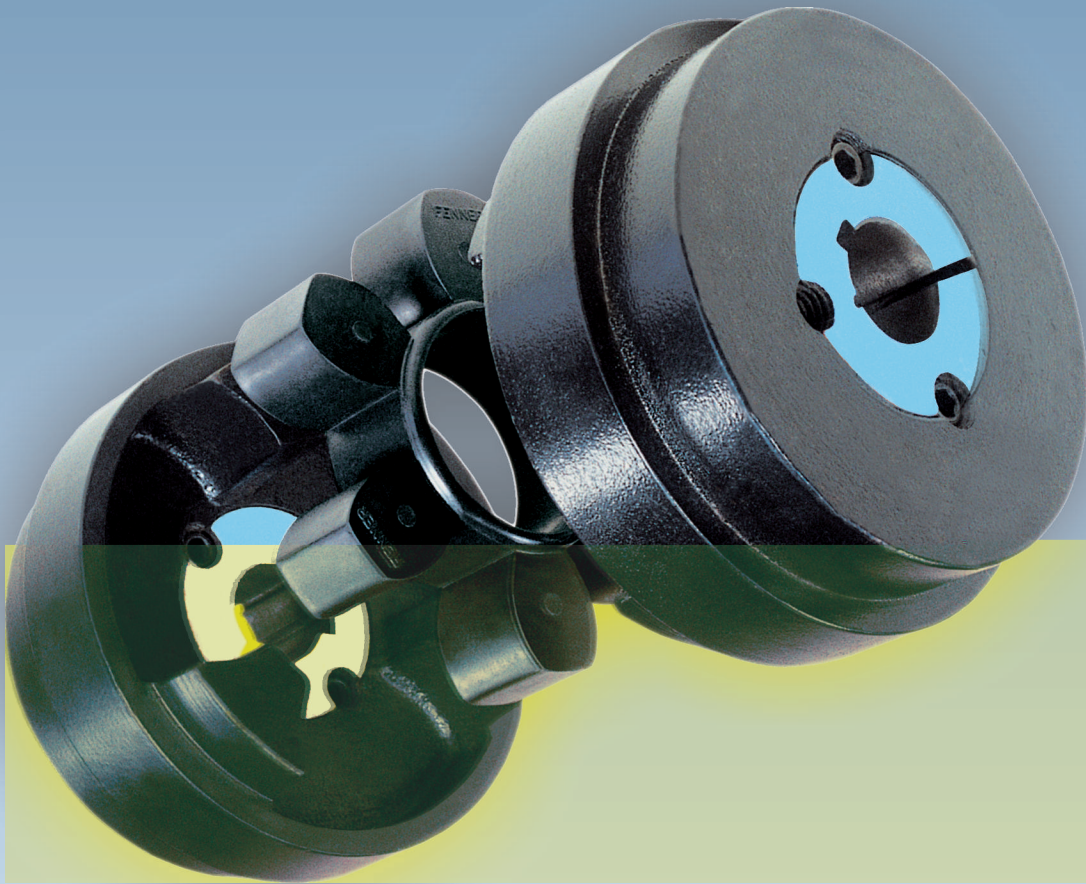

STAR COUPLINGS

STAR Couplings are essentially general purpose couplings with a flexible element which can accommodate higher degree of misalignment.

- Parallel misalignment upto 0.5 mm
- Axial misalignment upto 1.7 mm

Because of their superior design Star Couplings can accommodate larger shafts which make them a more economical proposition.

SALIENT FEATURES

ECONOMY	The design of the Star coupling has been optimised so that power capacities are balanced to the appropriate shaft diameters utilising Grip-Lock Bush fixing.
RESILIENCE	Transient peak loads are reduced by a flexible component, deflection of which is a prime design consideration.
MISALIGNMENT	Incidental parallel, angular and axial displacement of the connected shafts can be accommodated.
INSTALLATION	Quick and easy without special tools, only an allen key is required.
MAINTENANCE	Virtually eliminated and no lubricant is required.
ENVIRONMENT	The elastomeric component makes Star coupling suitable for use in most conditions within a temperature range of -40°C to + 100°C.
POSITIVE	In the unlikely event of the flexible component being destroyed, the drive will be maintained by the interaction of dogs which are integral with the flanges.

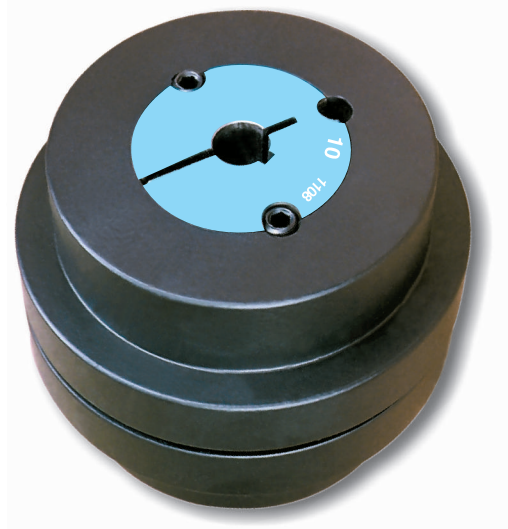

TABLE 1 - SERVICE FACTORS

SPECIAL CASES	TYPES OF DRIVING UNIT					
	Electric Motors Steam Turbines			Internal Combustion Engines Steam Engines Water Turbines		
	OPERATIONAL HOURS PER DAY					
DRIVEN MACHINE CLASS	8 and under	Over 8 to 16 inclusive	Over 16	8 and under	Over 8 to 16 inclusive	Over 16
For applications where substantial shock, vibration and torque fluctuation occur and for reciprocating machines, e.g. Internal combustion engines, piston type pumps and compressors, refer to Distributor with full machine details for torsional analysis.						
UNIFORM Agitators, Brewing Machinery, Centrifugal Blower and Compressors, Conveyors, Centrifugal Fans and Pumps, Generators, Sewage Disposal Equipment.	1.00	1.12	1.25	1.25	1.40	1.60
MODERATE SHOCK* Clay working machinery, Cranes Hoist, Laundry machinery, Wood working machinery, Machinery Tools, Rotary Mills, Paper Mill machinery, Textile machinery.	1.60	1.80	2.00	2.00	2.24	2.50
HEAVY SHOCK* Reciprocating conveyors, Crushers, Shakers, Metal Mills, Rubber machinery, (Banbury Mixers and Mills), Reciprocating compressors.	2.50	2.80	3.12	3.12	3.55	4.00

* It is recommended that keys (with top clearance if in Grip Lock Bushes) are fitted for applications where load fluctuation is expected.

STAR COUPLINGS

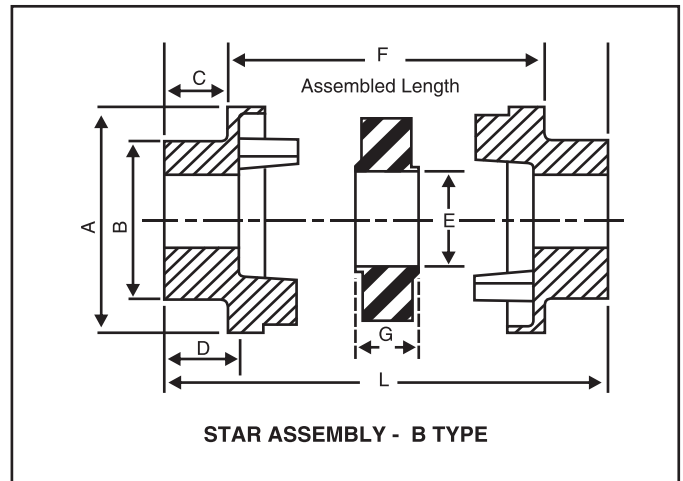
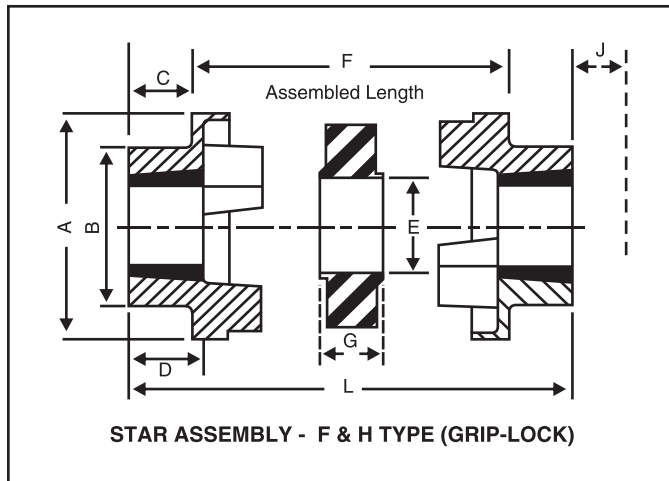
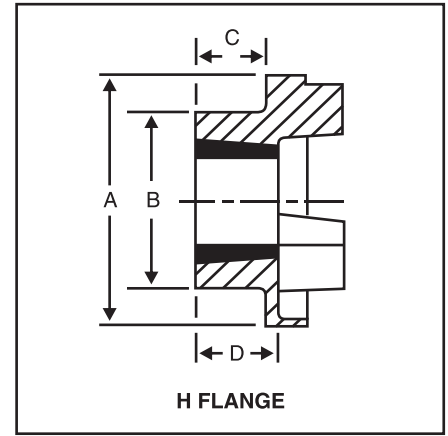
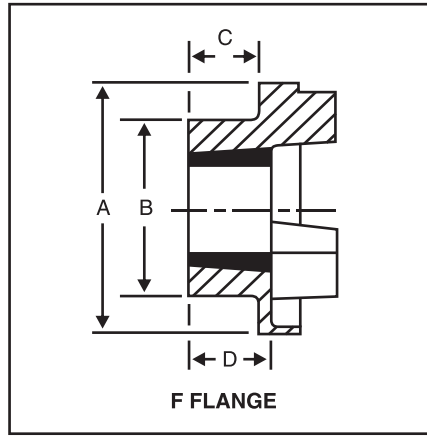
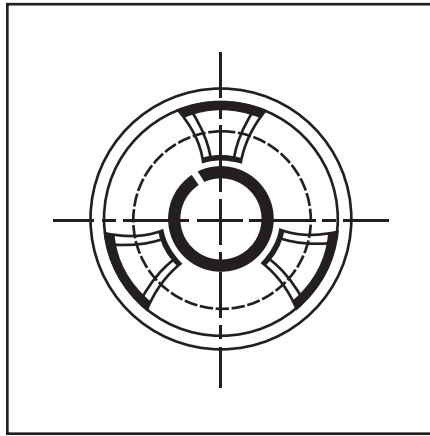

TABLE 2 - DIMENSIONS

Size	Power at 100 rpm kW	Type F & H								Type B						A	B	E	G
		TLB Size	Min. Bore	Max. Bore	C	D	F	L	J*	Min. Bore	Max. Bore	C	D	F	L				
70	0.33	1008	09	25	20.0	24	26.0	66.0	29	10	32	20	24	26.0	66.0	69	60	31	18.0
90	0.84	1108	09	28	19.5	24	31.5	70.5	29	10	35	26	30	30.5	82.5	85	70	32	22.5
110	1.68	1210	11	32	18.5	27	46.0	83.0	38	10	55	37	45	45.0	119.0	112	100	45	29.0
110A	1.68	1610	14	42	18.5	27	46.0	83.0	38	-	-	-	-	-	-	112	100	45	29.0
130	3.30	1610	14	42	18.0	27	54.0	90.0	38	14	60	47	56	54.0	148.0	130	105	50	36.0
150	6.28	2012	14	50	23.5	34	61.0	108.0	44	19	70	50	60	60.0	160.0	150	115	62	40.0
180	9.95	2517	16	60	34.5	47	74.0	143.0	48	35	80	58	70	73.0	189.0	180	125	77	49.0
230	20.90	3020	25	75	39.5	53	86.5	165.5	55	38	100	77	90	85.5	239.5	225	155	99	59.5
280	33.00	3525	35	90	51.0	67	106.5	208.5	67	48	115	90	105	104.5	284.5	275	206	119	74.5

* J - Wrench clearance to allow for tightening and loosening the bush on the shaft.

STAR COUPLINGS

Selection (Standard Electric Motors BS:3979 and IS:1231)

1. Read across the table 3 from the appropriate motor frame size and find the applicable nominal motor speed column.
2. Read the appropriate coupling selection for either Grip-Lock 'H' or 'F'

TABLE 3 - (Service Factors not less than 1.6)

Motor Frame Size	Shaft Dia. mm.	3000 rev/min		1500 rev/min		1000 rev/min		750 rev/min	
		Motor Power kW	Coupling Size	Motor Power kW	Coupling Size	Motor Power kW	Coupling Size	Motor Power kW	Coupling Size
90 S	24	1.5	70	1.1	70	0.75	70	-	-
90L	24	2.2	70	1.5	70	1.1	70	-	-
112 M	28	4.0	90	4.0	90	2.2	90	-	-
132 S	38	5.5 7.5	110 A 110 A	5.5	110 A	3.0	110 A	2.2	110 A
132 M	38			7.5	110 A	4.0 5.5	110 A 110 A	3.0	110 A
160 M	42	11.0 15.0	110 A 110 A	11.0	110 A	7.5	110 A	4.0 5.5	110 A 110 A
160 L	42	18.5	110 A	15.0	110 A	11.0	130	7.5	110 A
180 M	48	22.0	150	18.5	150				
180 L	48			22.0	150	15.0	150	11.0	150
200 L	55	30.0 37.0	180 180			22.0	180		
225 S	60			37.0	180			18.5	180
225 M	55 * 60	45.0	180	45.0	180	30.0	180	22.0	180
250 M	60 * 65	55.0	180	55.0	230	37.0	230	30.0	230
280 S	75			75.0	230	45.0	230	37.0	230
280 M	75			90.0	230	55.0	230	37.0	230
315 S	80			110.0	280	75.0	280	55.0	280
315 M	80			132.0	280	90.0	280	75.0	280

* 3000 rev/min only.

a. Service Factor

Determine the required service factor from Table 1.

b. Design Power

Multiply the normal running power by the service factor. This gives the Design Power which is used as a basis for coupling selection.

c. Coupling Size

Refer to Table 4 (page 5) and from the appropriate speed in the speed column, read across until a power equal to or greater than the design power required is found.

d. Bore Size

From the dimension Table 2 check that the chosen flanges can accommodate the required bores.

Example : A shaft coupling is required to transmit 70kW between a 1440 rev/min electric motor and a hoist running over 16 hours/day. The motor shaft is 70 mm and the hoist shaft is 75 mm.

a. Service Factor

From Table 1, the Service Factor is 2.

b. Design Power

Design Power : $70 \times 2 = 140$ kW

c. Coupling Size

By reading across from 1440 rev/min in the speed column of Table 4 (Power Rating Table) 143 kW is the first power to exceed the required 140 kW (design power). The size of coupling at the head of this column is 180.

d. Bore Size

By referring to the Dimension table 2 it can be seen that for S -180B type both shaft diameters fall within the bore range available. However in case the coupling selection is required in F&H type then select S-230 F&H type.

STAR COUPLINGS

TABLE 4 - POWER RATINGS (kW)

Speed Rev/Min.	COUPLING SIZE							
	70	90	110/110A	130	150	180	230	280
100	0.33	0.84	1.68	3.30	6.28	9.95	20.90	33.00
200	0.66	1.68	3.35	6.60	12.60	19.90	41.90	66.00
400	1.32	3.35	6.70	13.20	25.10	39.80	83.80	132.00
600	1.98	5.03	10.10	19.80	37.70	59.70	126.00	198.00
720	2.37	6.03	12.10	23.80	45.20	71.60	151.00	238.00
800	2.64	6.70	13.40	26.40	50.30	79.60	168.00	264.00
960	3.17	8.40	16.10	31.70	60.30	95.50	201.00	317.00
1200	3.96	10.10	20.10	39.60	75.40	119.00	251.00	396.00
1440	4.75	12.10	24.10	47.50	90.50	143.00	302.00	475.00
1600	5.28	13.40	26.80	52.80	101.00	159.00	335.00	528.00
1800	5.94	15.10	30.20	59.40	113.00	179.00	377.00	594.00
2000	6.60	16.80	33.50	66.00	126.00	199.00	419.00	660.00
2200	7.26	18.40	36.90	72.60	138.00	219.00	461.00	
2400	7.92	20.10	40.20	79.20	151.00	239.00	503.00	
2600	8.58	21.80	43.60	85.80	163.00	259.00	545.00	
2880	9.50	24.10	48.30	95.00	181.00	286.00		
3000	9.90	25.10	50.30	99.00	188.00	298.00		
3600	11.90	30.10	60.30	118.00	226.00			

TABLE 5 - PHYSICAL CHARACTERISTICS

Characteristic	COUPLING SIZE							
	70	90	110/110A	130	150	180	230	280
Maximum Speed* rev/min	8300	6740	5110	4400	3800	3180	2540	2080
Nominal Torque (Nm)	31.5	80	160	315	600	950	2000	3150
Maximum Parallel Misalignment (mm)	0.3	0.3	0.3	0.4	0.4	0.4	0.5	0.5
Maximum axial Misalignment (mm)	0.2	0.5	0.6	0.8	0.9	1.1	1.3	1.7

*Maximum coupling speeds are calculated using an allowable peripheral speed for the hub material. For selection of small sizes above 3600 rev/min - consult Distributor.

GRIP-LOCK BUSHES

Using Grip-Lock Bushes, it is possible for unskilled labour to achieve 'shrink fit' of Pulleys, Couplings, etc. on to shafts only using a hexagon wrench.

The arrangement of half-threaded holes and longitudinally split tapered bushes ensure maximum grip and fast, easy fitting. Tightening of the screws into the threaded holes in the hub forces the bush into the taper bored components, thereby effectively contracting the bore of the Grip-Lock Bush until the equivalent of a shrink fit is obtained. Grip-Lock Bushes are suitable for metric shafts and can also be supplied with Imperial Bores and Keyways.

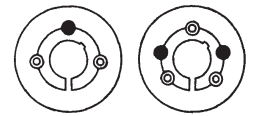

ADVANTAGES :

- No re-boring and keywaying costs.
- Saves time and cost in fitting.
- Eliminates precision taper fitting keys.
- 239 bush size/bore combinations are available.
- Interchangeable between many products.
- Taper bored components can be transferred to other diameter shafts by fitting alternative bore bushes.
- Convenience in dismantling for maintenance and component replacement.
- Accommodates shaft limits of +0.051 mm /-0.127mm.



The benefits of using Grip-Lock Bushes can be extended to include components which have a parallel bore by incorporating Grip-Lock Adaptors, Grip-Lock Bolt-on-Hubs or Grip-Lock Weld-on-Hubs.

Installation Instructions

INSERT BUSH INTO PULLEY OR COUPLING	INSERT SCREWS AND LOCATE ON SHAFT	TIGHTEN SCREWS FINGER TIGHT	TIGHTEN SCREWS ALTERNATELY

TO INSTALL

1. Remove the protective coating from the bore, outside of bush and bore of hub. After ensuring that the mating tapered surfaces are completely clean and free from oil and dirt, insert bush in hub, so that the holes line up.
2. Oil thread and point of grub screws, or thread and under-head of cap screws. Place screws loosely in holes threaded in hub, shown thus ① in diagram.
3. Clean shaft and fit hub and bush to shaft as one unit. Locate in position desired, remembering that the bush will grip the shaft first and then the hub will be slightly drawn on to the bush.
4. Using a hexagon wrench tighten screws gradually and alternately until they are fully secured. Use a piece of pipe on wrench to increase leverage.

TO REMOVE

1. Slacken all screws by several turns. Remove one or two according to number of jacking-off holes, shown thus ● in diagram. Insert screws in jacking off holes after oiling thread and point of grub screws or thread and under-head of cap screws.
2. Tighten screws alternately until bush is loosened in the hub and assembly is free on the shaft.
3. Remove assembly from shaft.
4. For normal drives a key is unnecessary. But when a key is not used hammer against large end of bush using a block or sleeve to prevent damage. (This will ensure that the bush is seated squarely in the bore). Screws will now turn a little more. Repeat this alternate hammering and screw tightening once or twice until correct tightening torque is obtained.
5. If a key is to be fitted, place it in the shaft keyway before fitting the bush. It is essential that only a side-fitting parallel key with TOP CLEARANCE be used.
6. After drive has been running under load for a short time stop and check tightness of screws.
7. Fill empty holes with grease to exclude dirt.

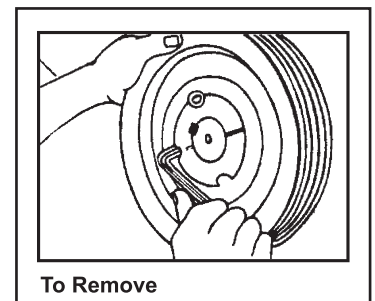

Bush		1008 1108	1310	1210 1215	1610 1615	2012	2517 2525	3020 3030	3525 3535	4040	4545	5050
Screw tightening torque (Nm.)		56	20	20	20	31	48	90	113	170	192	271
Screw	Qty.	2	2	2	2	2	2	2	3	3	3	3
Details	Size (BSW)	1/4"	3/8"	3/8"	3/8"	7/16"	1/2"	5/8"	1/2"	5/8"	3/4"	7/8"

GRIP-LOCK BUSHES

TABLE 6

METRIC BORES AND KEYWAYS

Bore Dia.	Keyway		Shallow Keyway Depth	Catalogue Code Group 029 ...																
	Width	Depth		1008 AO	1108 BO	1210 CO	1215 DO	1310 EO	1610 GO	1615 HO	2012 KO	2517 MO	2525 NO	3020 PO	3030 QO	3525 JO	3535 RO	4040 SO	4545 TO	5050 UO
9	3	1.4	-	...009	009															
10	3	1.4	-	...010	010															
11	4	1.8	-	...011	011	011	011													
12	4	1.8	-	...012	012	012	012													
14	5	2.3	-	...014	014	014	014	014	014	014	014									
16	5	2.3	-	...016	016	016	016	016	016	016	016	016								
18	6	2.8	-	...018	018	018	018	018	018	018	018	018								
19	6	2.8	-	...019	019	019	019	019	019	019	019	019	019							
20	6	2.8	-	...020	020	020	020	020	020	020	020	020	020	020						
22	6	2.8	-	...022	022	022	022	022	022	022	022	022	022	022						
24	8	3.3	1.3	...024*	024	024	024	024	024	024	024	024	024							
25	8	3.3	1.3	...025*	025	025	025	025	025	025	025	025	025	025						
28	8	3.3	1.3		028*	028	028	028	028	028	028	028	028	028						
30	8	3.3	-			030	030	030	030	030	030	030	030	030						
32	10	3.3	1.3			032*	032*	032	032	032	032	032	032	032						
35	10	3.3	1.3					035*	035	035	035	035	035	035	035					
38	10	3.3	-						038	038	038	038	038	038	038	038	038			
40	12	3.3	1.3						040*	040*	040	040	040	040	040	040	040	040		
42	12	3.3	1.3						042*	042*	042	042	042	042	042	042	042	042	042	
45	14	3.8	-							045	045	045	045	045	045	045	045	045	045	
48	14	3.8	-							048	048	048	048	048	048	048	048	048	048	
50	14	3.8	2.8							050*	050	050	050	050	050	050	050	050	050	
55	16	4.3	-								055	055	055	055	055	055	055	055	055	055
60	18	4.4	-								060	060	060	060	060	060	060	060	060	060
65	18	4.4	-									065	065	065	065	065	065	065	065	065
70	20	4.9	-									070	070	070	070	070	070	070	070	070
75	20	4.9	-									075	075	075	075	075	075	075	075	075
80	22	5.4	-										080	080	080	080	080	080	080	080
85	22	5.4	-										085	085	085	085	085	085	085	085
90	25	5.4	3.4										090*	090*	090	090	090	090	090	090
95	25	5.4	-												095	095	095	095	095	095
100	28	6.4	5.4													100*	100	100	100	100
105	28	6.4	-																105	105
110	28	6.4	-																110	110
115	32	7.4	-																	115
120	32	7.4	-																	120
125	32	7.4	-																	125
Nominal dia at large end of Taper				35.0	38.0	47.5	47.5	51.0	57.0	57.0	70.0	85.5	85.5	108.0	108.0	127.0	127.0	146.0	162.0	177.5
Approx. Mass of Bush (Kg)				0.1	0.1	0.2	0.3	0.3	0.3	0.5	0.7	1.5	1.9	2.7	3.6	3.8	5.0	7.7	10	14

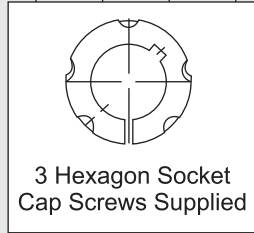

Dimensions in millimeters

Keyways are British Standard Metric B.S. 4235: Part 1:1972 and conform to I.S.O. recommendations except for the bore sizes marked * which are shallower.

Where a key is to be used it should be parallel and side fitting with top clearance. Depth of keyway is measured at CENTRE.

Note : Grip - Lock Bushes with imperial bores can also be supplied. Please consult Distributor.

OUR PRODUCT RANGE



Manufactured by:

Fenner (India) Limited

480 Anna Salai, Khivraj Complex II
Nandanam, Chennai - 600 035, India
Tel : +91 44 24312450, Fax : +91 44 24320193
Email : fenner_india@fennermail.com
Website : www.fennerindia.com