

20.014

Gauging Displays & Controllers



PneuControl / Smart Control Controllers

Specially designed to cater the need of automation of gauging systems and online Statistical Process Control. Allows to connect Multi Channel Gauging system suitable for Air gauges or Inductive probe gauging.

Features :

- State-of-art displays which cater to emerging needs of **Industry 4.0** requirements. Compact design with very small foot print ensures space saving on the shop- floor particularly
- Based on latest **SoC technology** which offers computer power. Designed on **embedded technology** which ensures virus free protection.
- Auto detection of measuring gauge.
- Operational software and data on industry grade flash memory ensures robustness and eliminates fear of hard disk crash.
- Offers flexibility of programming & storing 99 measurement programs with Part information and dimensional data, program can be recalled easily.
- User can configure their own measurement using the arithmetic formula editor.
- Measured data can be sent to central server over cabled LAN / wireless LAN. Data can be collected in Q-DAS which is globally accepted statistical analysis software approved by most of the Automotive Industry.
- Empower the user by enabling to configure the measurement screen for simultaneous or sequential measurement by offering features like “Auto Cycle” and “Measurement Cycle” . Screen can be user configured to display statistical parameters like Cp, Cpk, Job counters Produced v/s measured.
- Data sorting / Grading up to 25 grades.
- Based on the measured values user can further control the machine automatically by applying conditions like “Machine stop” and measured data output to Machine Controller for “Automatic tool offset correction”.
- Pneu Control has highly stable performance with variation in Air pressure (Operating Air Pressure Range 3.5 - 6 bar) . Auto air cut-off while gauge not in use.



SmartControl
Gauging Display + Controller

PneuControl
Gauging Display + Controller

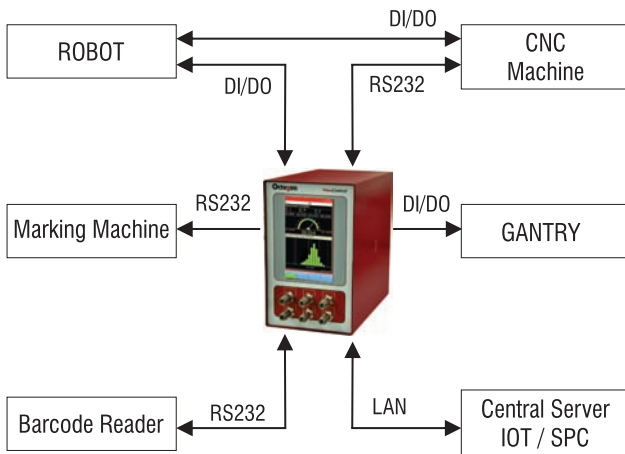

- Ability to communicate with the Machine, Robots, Gantry and Marking machines simultaneously is the core strength which makes them front runners for **Industry 4.0**.
- Can parallelly communicate to **IoT software** and **SPC software** for cloud computing. Can handshake with Robots for mechanized manufacturing too.



*Auto Air Cut-off Facility

Technical Specifications:	PneuControl	SmartControl
Input Channels	1 / 2 / 3 / 4 / 5 / 6 Nos. Piezo sensors	2 / 4 / 6 / 8 Nos. Inductive sensors
Resolution	0.1 μ m / 1 μ m	
Units	mm	
Measurement Modes	CUR, MIN, MAX, TIR, AVG.	
Output Results	Maximum up to 32 per Part Setup	
Part Setup	Maximum up to 100	
Result formula editor	Result formula can be edited for combinations of Pneumatic channels and / or other results.	
Indications	Pass, Fail, Warning	
Calibrations	Single master/ Double master configurable	
User Interface	7" Colour LCD display (Dot Matix : 800 x 480 x RGB) with resistive touch	
PC Interface	2 x RS-232,1;Ethernet	
USB host interface	USB 2.0 Compliant	
Digital Inputs / Outputs :	8 inputs + 8 outputs, Opto Isolated	
Footswitch interface	F1, F2; F3, F4	
Display Views	Digital Readout / Dial / Run Chart	
Memory	In built micro SD card of 4 GB for data storage (Contact manufacturers for additionsl storage capacity)	
SPC	Cp, Cpk, Pp, Ppk Calculations, Charts, X-R, X-S, Histogram	
Job Counters	OS/ US/ OK/ NG/ TM/ TP	
Reports Save	Shift/ datewise	
Reports access	Thumb drive/ Lan (with Smart Client Utility)	

Multi Channel / Single Channel Air-Electronic Gauging Displays



Pneu-Measure
Single channel air electronic gauging display



Pneu-Auto Measure
Multi channel air electronic gauging display

Octagon 'Pneu Auto Measure' and 'Pneu Smart Measure' are multi channel air gauging display units featured with auto detection of channel input. Both units have built in PIEZO sensor suitable to be used with different pneumatic gauges e.g. Air Plug Gauges , Air Ring Gauges , Air caliper Gauges of various makes.

This feature facilitates you to use single unit at the gauging station where multiple air plugs / air snap / air rings are used for measurement of multiple parameters of a component. Both models are provided with auto air cutoff facility to save air consumption while gauge is not in use.

Pneu Smart Measure have added feature with graphical display which facilitates analogue (Dial type) indication along with graphs for Run Chart .

Octagon also offers **Pneu Measure** a single channel Digital Display with built in PIEZO sensor suitable to be used with different pneumatic gauges e.g. Air Plug Gauges , Air Ring Gauges , Air caliper Gauges of various makes.



Pneu-Smart Measure
Multi channel air electronic gauging display

Technical Specifications:	Pneu measure	Pneu Auto measure	Pneu smart Measure
Input Channels	1	3 / 4	3 / 4
Display function	N/A	Auto detection of channel input using proxy sensors	
Air sensor	Piezo Type		
Display type	1/2" LED numeric Display	7" LCD graphical display	
Readout	Absolute / comparative		
Air cut off facility	N/A	Automatic with external sensor box	
Modes of operation	Current / Max / Min / Difference		
Display Form	7 Segment Numeric		Analogue Dial and Graphical Run chart
Least count	0.1 μm / 1.0 μm		
PC Communication	RS232		RS232 Port / USB port / Ethernet Port
Data storage memory	N/A	4 GB data storage in ".csv" format	
Data storage	N/A	using foot switch	

Multi Channel / Single Channel Electronic Gauging Displays

Octagon's digital displays are single / multi channel digital displays suitable for gauging applications especially for multi gauging systems with Inductive sensors.



Octa-Gage
Multi channel electronic gauging display

Technical Specifications:	
Input Channels	2/4/6/8 LVDT Channels
Type	Standard/ Fanuc Interface (OctaGage Transmit data to Fanuc controller O-I / Power Mate / 16 / 18 Series)
Resolution	0.1 μm / 0.2 μm 0.5 μm , 1 μm / 2 μm / 5 μm / 10 μm
Units	mm
Setup	100
Measurement Modes	Current, Min, Max, TIR, AVG
Result Formula Editor	Result formula can be edited for combinations of LVDT channels and / or other results
Indications	Pass, Fail, Warning
Calibration	Single / Double Master configurable
Scaling	Auto / Manual
User Interface	USB 2.0 Compliant (for mass storage device)
PC Interface	RS-232, RS-485, Ethernet (For Firmware Upgrades Only)
Digital Input / Outputs	8 Inputs + 8 Outputs, Isolated, Open collector
Digital Views	Digital Readout / Dial/ Bar graph / Run Chart
Memory	Inbuild micro SD card of 4 GB for data storage
Footswitch interface	Available

Multi Channel / Single Channel Electronic Gauging Displays

Octagon's digital displays are single / multi channel digital displays suitable for gauging applications especially for multi gauging systems with Inductive sensors.

Seven segment displays, the user can set it for measurements in comparative mode. 2 point auto calibration facility makes calibration easy & quick. Flexibility in settings makes the column a real versatile tool for quality checking for mass production of work pieces.



Single / Multi Channel
Digital Display for Inductive sensors

Technical Specifications:		Display	1 line - 6 Digit 7 Segment
Input Channels	1/ 2/ 4/ 8	Footswitch	Available
Measurement	Static/ Dynamic Reading	Scale	mm, inch
Readout	Absolute/ Comparative measurement	Resolution	5.0µm, 1.0µm, 0.5µm, 0.1µm.
Modes	Current, Max, Min, TIR (ID/ OD)	Measuring Range	0.1 µm -9.9999mm to 99.9999 mm 1 µm -99.999mm to 999.999 mm
Calibration	2 point Auto calibration		
PC Interface	RS-232		

Column Gauge Displays

Octagon's tri-colour bar graph **Air Electronic Column Gauge** is an electronic gauge with PIEZO sensors suitable to be used with Pneumatic gauges e.g. Air Plug gauges, Air Ring Gauges, Air Caliper Gauges.

Octagon also offers tri-colour bar graph **Electronic column Gauge** suitable for gauging systems provided with inductive (LVDT) sensors.

The tri-colour bar graph along with the seven segment display is an easy tool for the operator to improve productivity. The user can set it for measurements in comparative mode. The tri-colour bar changes colour between green, red and yellow depending on the component status- OK, REJECT or REWORK.

The tolerance values are superimposed on the bar for operator's assistance. Advanced microcontroller based hardware along with a very simple to understand menu makes it very user friendly. 2 point auto calibration facility makes calibration easy & quick. Flexibility in settings makes the column a real versatile tool for quality checking for mass production of work pieces.



Electronic Column Gauge :
Gauging Display

Technical Specifications:	Electronic Column Gauge	Air Electronic Column Gauge
Input Sensor	Inductive Electronic Sensor	Piezo Air Sensor
Input Channels	1	1
Measurement	Static/ Dynamic Reading	
Readout	Absolute/ Comparative measurement	
Bar graph	Single Tri-Colour LED for component status. (Red-Reject, Green - OK, Yellow- Rework)	
Bar graph ranges	10, 25, 100, 250, 500	
Sound Signal	Buzzer for out of tolerance value.	
Modes	Current, Max, Min, TIR (ID/ OD)	
Calibration	2 point Auto calibration	
PC Interface	RS-232	
Display	6 Digit 7 Segment	
Footswitch	Available	
Scale	mm, inch	
Resolution	F1, F2, F3, F4	
Measuring Range	0.1 µm -9.9999mm to 99.9999 mm 1 µm -99.999mm to 999.999 mm	



PIEZO sensor based Air Column Gauge :
Gauging Display