

ONYX TECHNOLOGY

COMPLETE ENGINEERING SOLUTION

This is one of the best solution to your Complete Engineering Requirements. We are please to introduce ourselves as leading industry engaged in manufacturing of sheet metal components, fabrication works , Powder Coating ,Rubber Components , and Plastic Components.

We are manufacturer and supplier of press tool and fabrication for sheet metal components and having facilities of 2D laser cutting, CNC press brake, Press m/c, CNC Machining etc with our sister concern.

Onyx Technology 2015-2016

Onyx Technology establish on 1st May 2015

- Shop Area – 150 Sq. Ft.
- No Employee – 2 Nos
- Customer – SS, Toolroom Engineering Services, I Stron Car Parking, Sudhir Power.



Onyx Technology 2016-2017

- Shop Area – 1200 Sq. Ft.
- No Employee – 6 Nos
- Customer – DMI Draexlmaier Manufacturing India, KSPG Automotive Pvt. Ltd, ruhlamat Automation Technologies (I) Pvt, Ltd ,SS, Laxmi , Toolroom Engineering Services ,PMT Machine Tool, Ask Engineers, Suverna FibroTech .



Onyx Technology 2017-2018

- Shop Area – 4000 Sq. Ft. Closed & 2000Sq. Ft. Open .
- No Employee –14 Nos
- Customer – CNH Industrial (India) Pvt Ltd, Hyosung T&D India Ltd, DMI Draexlmaier Manufacturing India, KSPG Automotive Pvt. Ltd, ruhlamat Automation Technologies (I) Pvt, Ltd ,SS, PMT Machine Tool,Ask Engineers, Suverna FibroTech, Ulka.



Onyx Technology 2018-2019-2020

Unit 1 – 4000 Sq. Ft. Closed
& 2000Sq. Ft. Open



Unit 2 – 12000 Sq. Ft. With
10 Ton Capacity Crane



Engaged in Manufacturing of Sheet Metal Components



Products:

1. Sheet Metal Parts
2. Press Parts
3. Machining Parts
4. Material Handling Equipments

Services:

1. Design and Development
2. Fabrication
3. 2D laser
4. CNC Bending
5. Tool-Room and Press m/c
6. Powder Coating
7. Sand Blasting & Painting

VISION AND TARGETS

Strategy Targets

We expect and demand the best we have to offer by always keeping Onyx Technology's values at the top of mind.

Process Targets

We will earn our customers' delight through continuous improvement driven by the integrity, teamwork, and innovation of production process.

Business Targets

From the MD's desk our goals is to achieve our target at the end of 2020-21 financial year . Also become one of the best development centre in automobile industry.

EnviromentalTargets

We are bound with polution free enviroment & its our responcibility to keep it clean,green & healthy.

BUSINESS STRATEGY

Business Strategy

- Customization and Commitment
- Integrity
- Standardization
- Learning and Growth

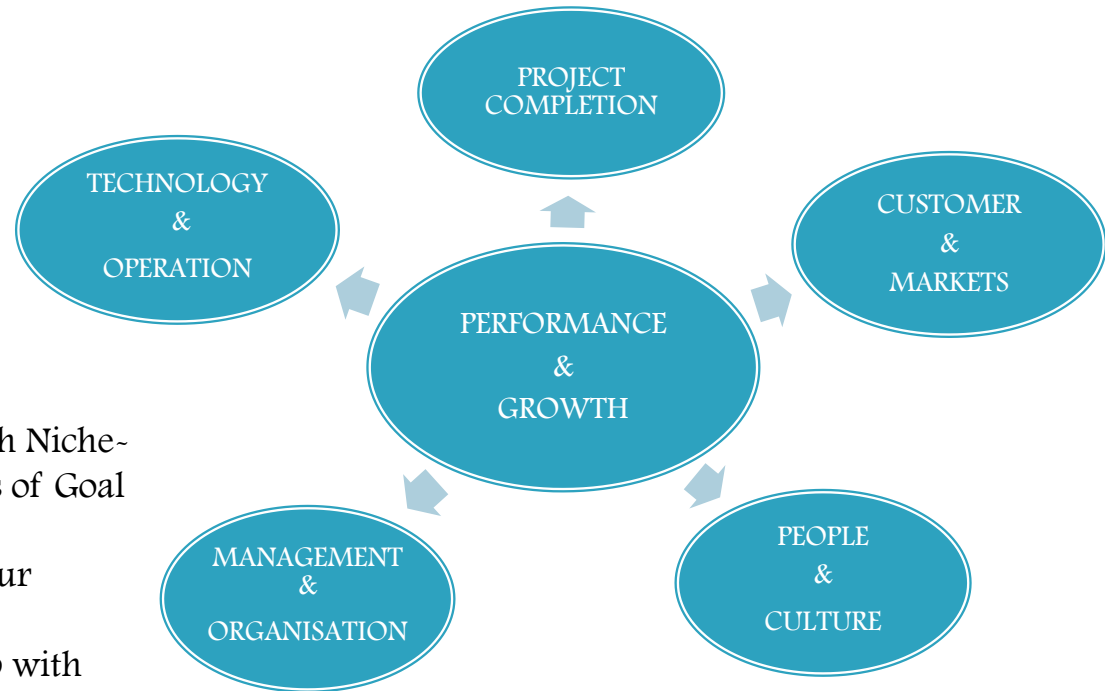

➤ Customer focused product development through Niche-marketing and Commitment is the key for success of Goal Congruence.

➤ Business Strategy for Pivotal Value addition to our Customers and Employees.

➤ We are highly adaptable to change & to keep up with the state of art technology to sustain our business

PRINCIPLES FOR PROCESS

- We always keep in mind at the time of deciding the process the optimum use of **5M** (man, machine, material, method & measurement) for development and procurement of products.
- Minimize the rejection on shop floor by applying **5S** (Sorting, Straightening Out, Standardizing, Sweeping, Sustaining the Practice).
- Cost Analysis, Quality improvement, and delivery in time and proper Resource allocation judiciously.
- Use of sophisticated software's, Training of employees, Research and Development has significant relationship with performance.

PROCESS FLOW CHART FOR DEVELOPMENT

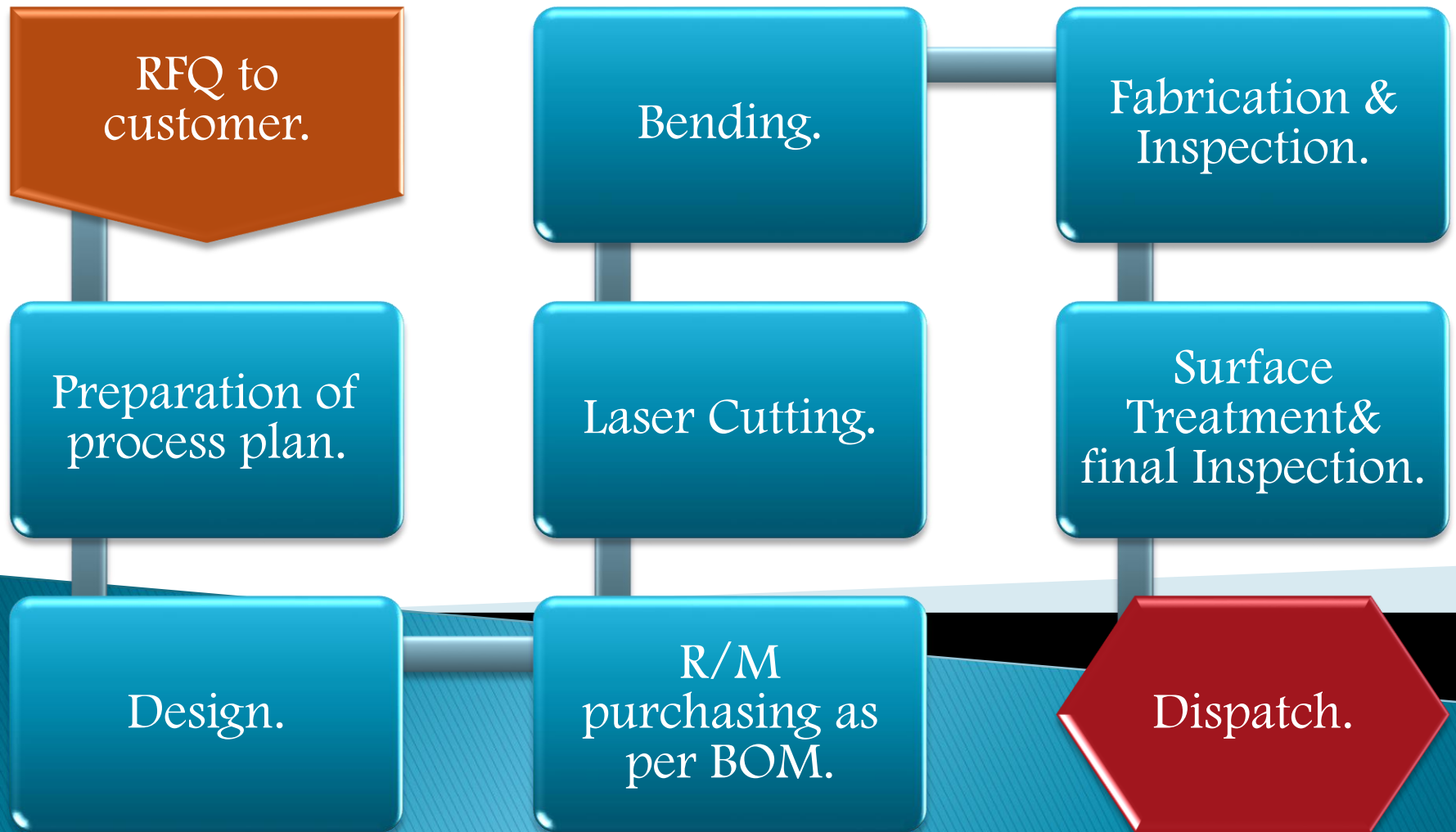

FABRICATED ASSY PROJECT PARTS

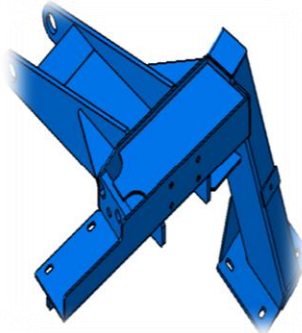
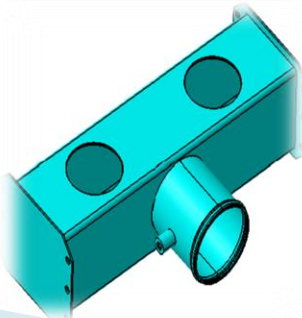
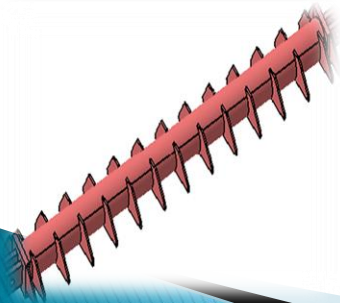
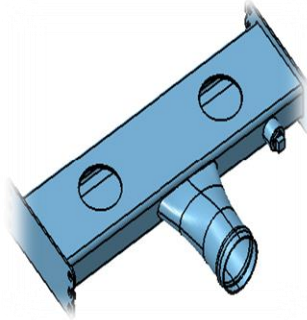
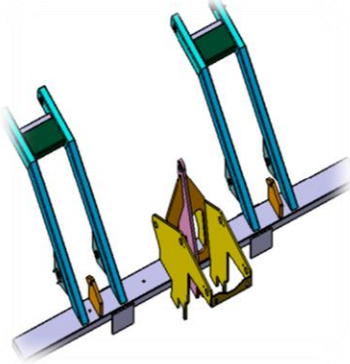
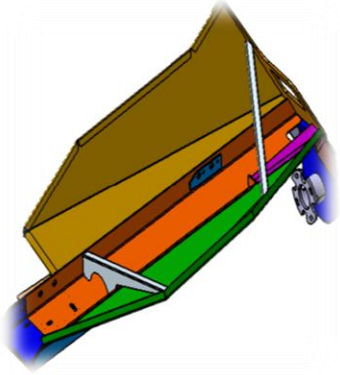
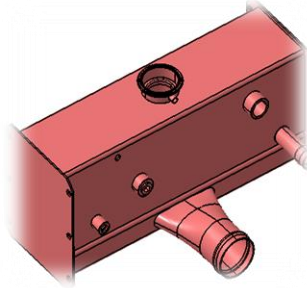
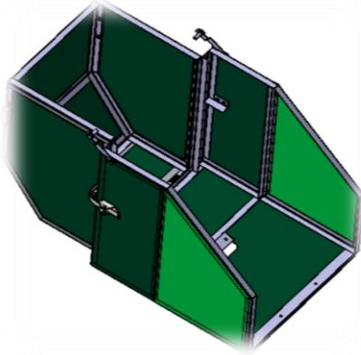
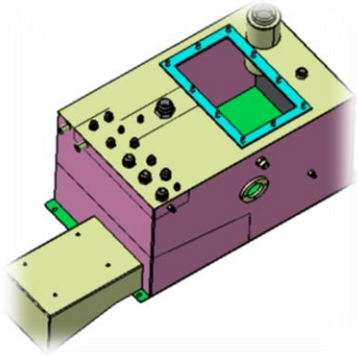

Fabrication Parts With Laser Bending

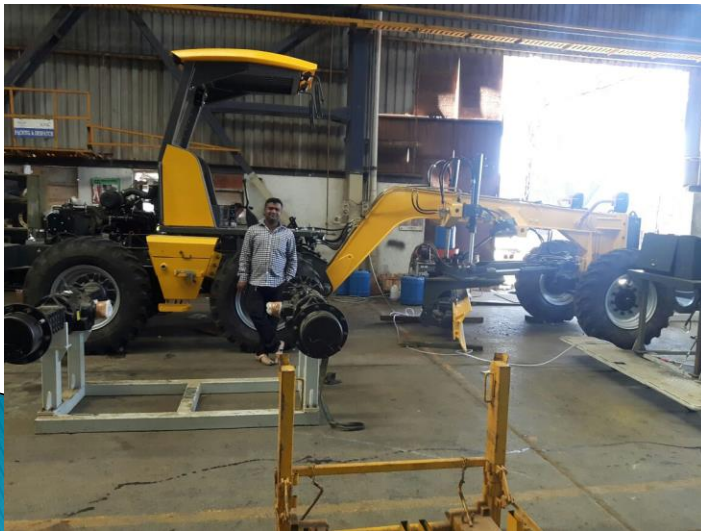

Laser Bending Parts



Fabrication Parts With Laser Bending



Pipe Diameter-OD-1392mm,Thk-10mm,Length-5700mm

Material Handling



Material Handling



Material Handling



Fabrication Parts With Laser Bending



Fabrication Parts



Fabrication Parts



Press Tools

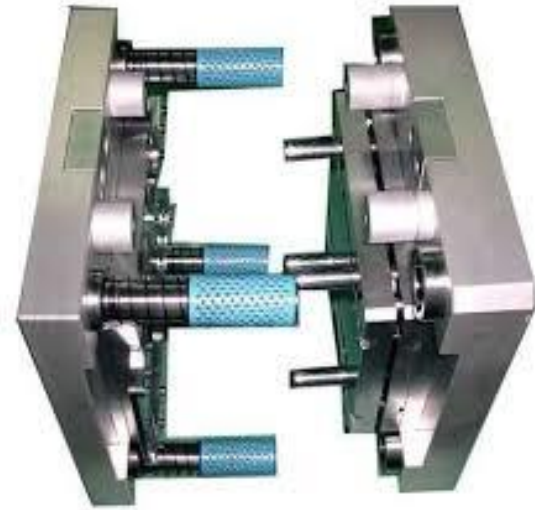

Casting Jobs



Interior Parts

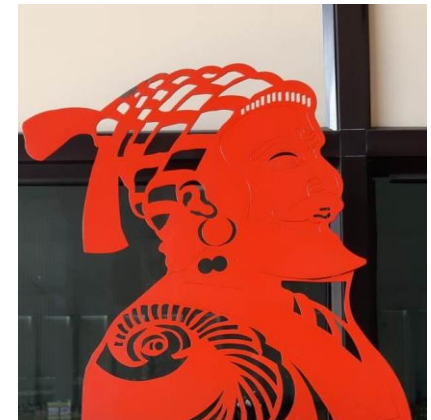
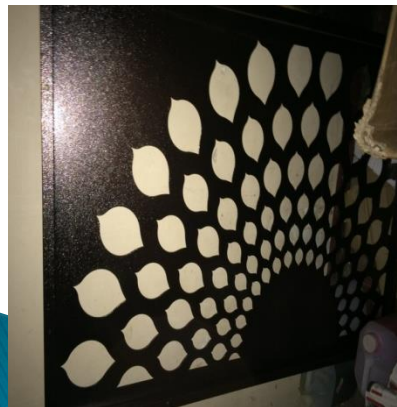
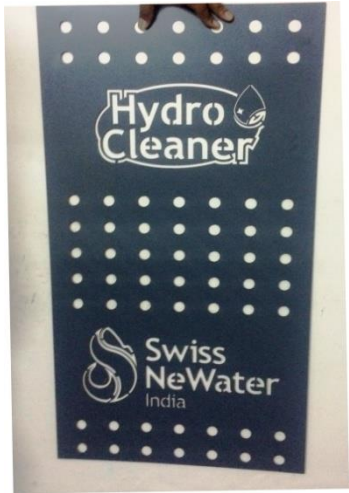

ISO Certificate



CERTIFICATE

This is to certify that management system of

ONYX TECHNOLOGY

Registered Office: S. No. 192/1, Chakrapani Vasahat, Shivshankar Colony No. 2, Bhosari, Pune - 411039 (Maharashtra) India
Factory: Plot No. 162, J Block, MIDC, Bhosari, Pune - 411026 (Maharashtra) India

Has been assessed by SYSTEM TRAINING & ASSESSMENT REGISTRAR
and found to be in accordance with the requirements of standard detailed below

ISO 9001:2015 (Quality Management System)

This Certificate is valid for following scope

Development, Manufacture & Service of Proto Type Products in Sheet Metal, Rubber & Casting
Manufacture of Precision CNC Machined Components, Fabricated Sub - Assemblies and
Material Handling Equipments for Automotive & Engineering Industries

Certificate No. 182/2017
Issue Date:- 25/05/17
Expiry Date:-24/05/20



A. Kumar

Auth Sign
System Training & Assessment Registrar
Mail:-info@stariso.com, Web:- www.stariso.com



- This Certificate is Property of STAR and can be maintained through surveillance and renewal audits.
- In case of non compliance, this Certificate must be returned to STAR.
- You can verify the validity of this certificate at www.stariso.com

MSME Certificate

6/24/2019

https://udyogaadhaar.gov.in/UA/PrintApplication.aspx

B		Type of Enterprise	Micro	Small	Medium
		Manufacturing	A	B	C
		Services	D	E	F
		UAM No.	MH26A0009088		

Udyog Aadhaar Memorandum

- Aadhaar Number: 863057105953
- PAN Number: AAFO4054E
- Name of Entrepreneur: SWAPNIL RAMESH KUMBHAR
- Social Category of Entrepreneur: OBC
- Gender: Male
- Physically Handicapped: No
- Name of Enterprise: ONYX TECHNOLOGY
- Type of Organization: Partnership
- Location of Plant Details

SN	Flat/Door/Block No.	Name of Premises/Building Village	Road/Street/ Lane	Area/Locality	City	Pin	State	District
1	PLOT NO, 392,	J-BLOCK,	MDC,	BHOSARI	PUNE	411026	MAHARASHTRA	PUNE

Official Address of Enterprise: SR NO.192/1,SHIVSHANKAR NAGAR,COLONY NO.2,CHAKRAPANI VASAHAT BHOSARI PUNE 39

- | | | | | | |
|------------|------------|--------|----------------------------|------|--------|
| District: | PUNE | State: | MAHARASHTRA | PIN: | 411039 |
| Mobile No: | 7588576392 | Email: | onyxtechnology15@gmail.com | | |
- Date of commencement: 01/06/2015
- Previous Registration details if any: ::
- Bank Details

IFS Code:	TJSB0000034
Bank Account:	034120100005568
- Major Activity: MANUFACTURING
- | SN | NIC 2 Digit | NIC 4 Digit | NIC 5 Digit Code | Activity Type |
|----|---|---|--|---------------|
| 1 | 25 - Manufacture of fabricated metal products, except machinery and equipment | 2511 - Manufacture of structural metal products | 25113 - Manufacture of industrial frameworks in metal (frameworks for blast furnaces, lifting and handling equipment etc.) | Manufacturing |
- Persons employed: 15
- Investment (Plant & Machinery/ Equipment's): 140(Rs. In Lakhs)
- District Industry Centre: PUNE

Declaration
I hereby declare that information given above is true to the best of my knowledge. Any information, that may be required to be verified, shall be provided immediately before the concerned authority.

MyMsme Mobile App (Beta Version) is available now for download. <https://play.google.com/store/apps/details?id=msme.mymmsme>

WHY US?

Services:-

We provide services in laser cutting , CNC Bending , Fabrication for which we have arranged Tooling & Tool Design, CNC Machining.

Our Laser cutting max capacity. Of Upto16mm for MS Material & Upto8mm For SS Material.

Quality:-

Company is certified by **ISO 9001:2015(Quality Management System)**

We are very Concern about Parts Quality for that we will appoint a quality person for maintaining Parts quality. We also have all types of Quality checking. We will be purchasing Material from approved and well-known sources. Every lot will be checked by Grade Test.



Goals and Objectives

- Customer should be satisfied by their given Requirements.
 - Zero Base Rejection.
 - Being a First preference of each customer.
 - Maintaining a good and Healthy relationship with Clients.
 - Being a well known company in Industry's.
- 

Our Machines

CNC Laser
Machine

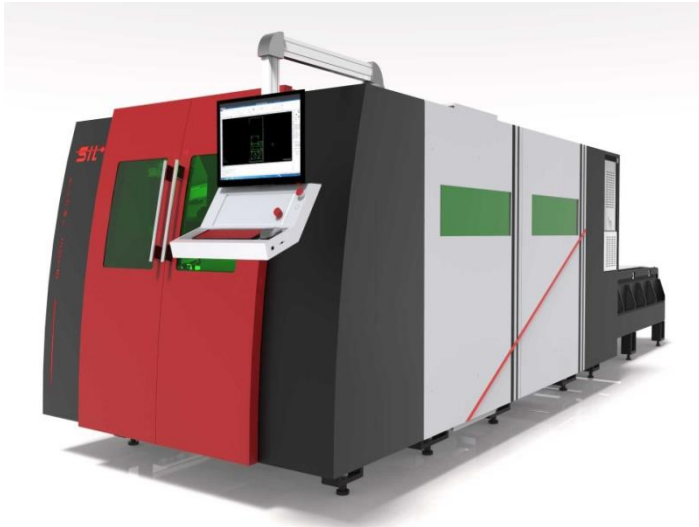

CNC Bending Machine



Press Machines





COMPANY REGISTRATION DETAIL

Gst No : 27AAEFO4054E1ZG
Name of Bank : UCO Bank
Branch : Pimpari MC
Cash Credit Account No : 19700510000175
IFSC Code : UCBA0001970
EMAIL ID : onyxtechnology15@gmail.com

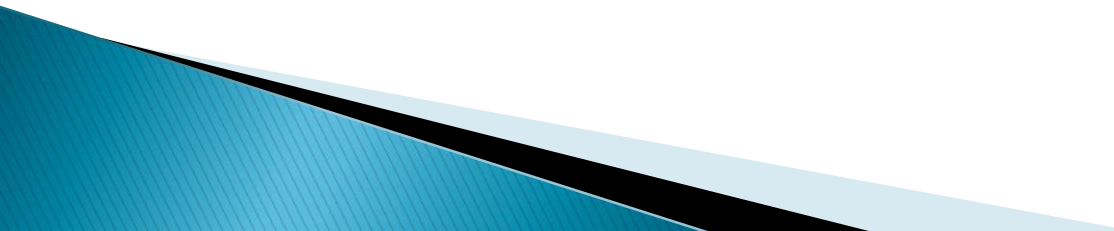

CONTACT US

Contact Person ~ Mr. Swapnil Kumbhar , Mr. Amol Shelke .
Contact ~ + 91 7588576392, +91 8087930392.
Email id ~ onyxtechnology15@gmail.com
Web Site ~ www.onyxtechnology.in
Work Address ~ Unit 1 ~ J -392 J-Block, MIDC Bhosari 26
Unit 2 ~ J -162, J-Block, MIDC Bhosari 26

THANKING YOU!!!!

Our Valuable Customers

