

PARASON TRAPMAGNI

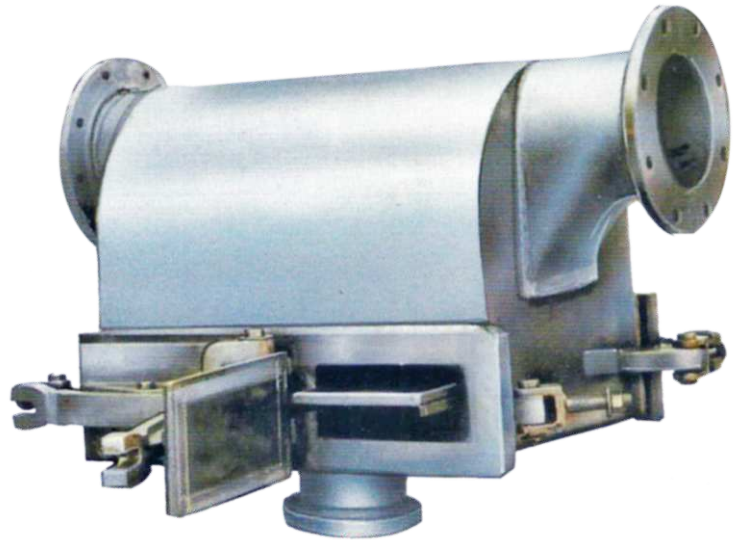

Cross Sectional View

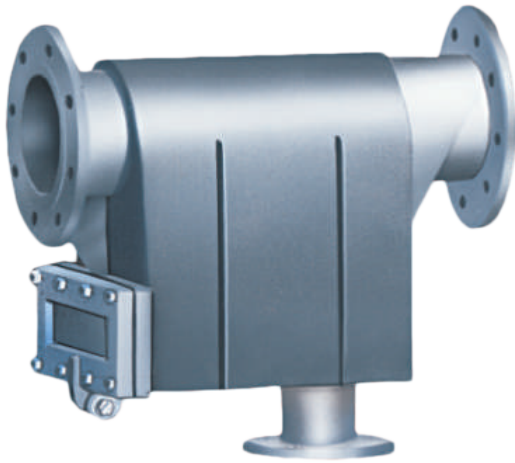
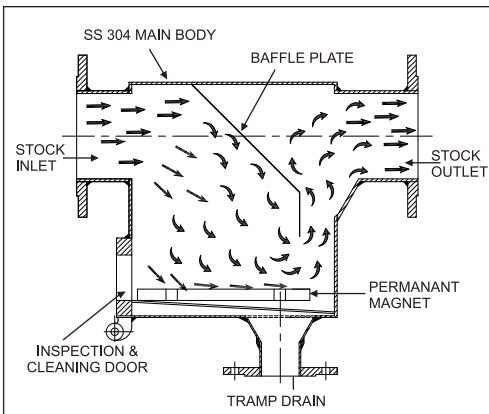

PARASON TRAPMAGNI

- Sturdy, fabricated stainless steel construction.
- Large permanent magnet for more contact area hence improved removal efficiency.

For 6" - One magnet
8" & 12" - Two magnets

- Well shaped body assets other non magnetic tramps for gravity.
- Periodic cleaning mark easy through cleaning door and tramp drain:
- Provision of tray over the concealed magnet for fast cleaning.
- Auto arrangements gives excellent results.

- Size
Trapmagni 6 - 50 TPD
Trapmagni 8 - 80 TPD
Trapmagni 12 - 140 TPD

MAIN FEATURES:

- Main body is SS-304
- No moving parts
- No flush water
- No energy consumption
- Maintenance free
- Easy installation
- Upto 6 bar operating pressure
- 1 year guarantee

* Above products are patented design registry, copyright, trademark.
* Due to constant research and development specification are subject to change

On Line Auto Control Mechansim With Fiber Recovery System

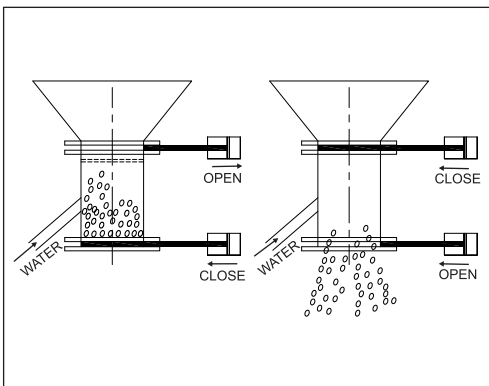

PARASON MACHINERY (I) PVT. LTD.

PARASONS HOUSE, 28, VENKATESH NAGAR, OPP. JALNA ROAD, AURANGABAD-431 001. (INDIA)

TEL. : +91 (0) 240 - 2339234/35/36/37, FAX:+91 (0) 240 - 2332944

CUSTOMER SERVICE NO. : +91 (0) 240 - 66 44 444, 6644200

Web : www.parasonmachinery.com E-mail : info@parasonglobal.com

Web : www.parasonglobal.com E-mail : parason@parasonglobal.com

Parason... Leader in stock preparation