

② 4 THREADED HOLES, M3X5 DEEP  
EQUISPACED AS SHOWN ON 28.0/28.2 PCD.

MOTOR WIRE

REF.	A MAX.	WEIGHT
AA	86.0	0.4 KG.
AB	122.0	0.6 KG.

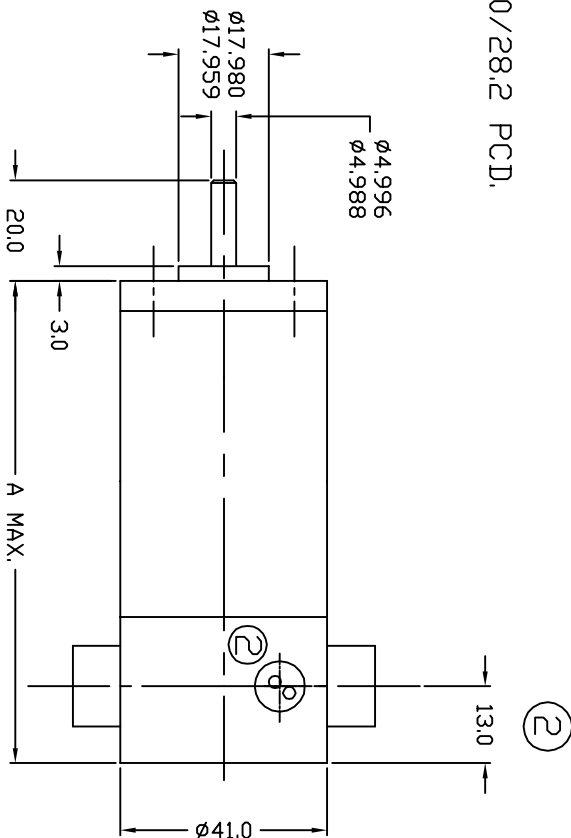

NOTES: PLEASE SEND APPROVAL COPY WHILE ORDERING.  
ALL UNSPECIFIED TOLERANCES WITHIN ±3% LIMIT

INDEX	REVISION	DATE	SIGN	MODEL: AA, AB	WEIGHT: AS ABOVE	DRN.	VTK.	03-07-06	
②	Dimens. #20.13 WAS 15.17& GRUMMET ADDED	24/07/11		Manufactured by- <b>PRANSHU ELECTRICALS PVT. LTD.</b> D15, MIDC, WALLUJ AURANGABAD-431 136 (INDIA)		CKD.	SMK.	03-07-06	
①	Dimens. 60.0 WAS 68.0	4-10-08				APPD.	VVH.	03-07-06	TITLE <b>OUTLINE DRAWING</b>
									MATL: -
									DRG. NO.
									<u>AAOL002/2</u>