

HEAT SHIELD PART PRESENTATION



COMP. NAME:-SHIELD EXH MUFF FRT HT

MAT:-SS, AL, Elrotherm 100

COMP SIZE:- 1055* 282*95.

OPERATION SEQUENCE:-

BLANKING DIE
(SS;AL, Elrotherm 100
. 3 STN)

**FLANGE 90° ,45°
&FLANTNING DIE**
(3STN)

FORM & PIERCE DIE
(2 STN)



FORM & PIERCE DIE

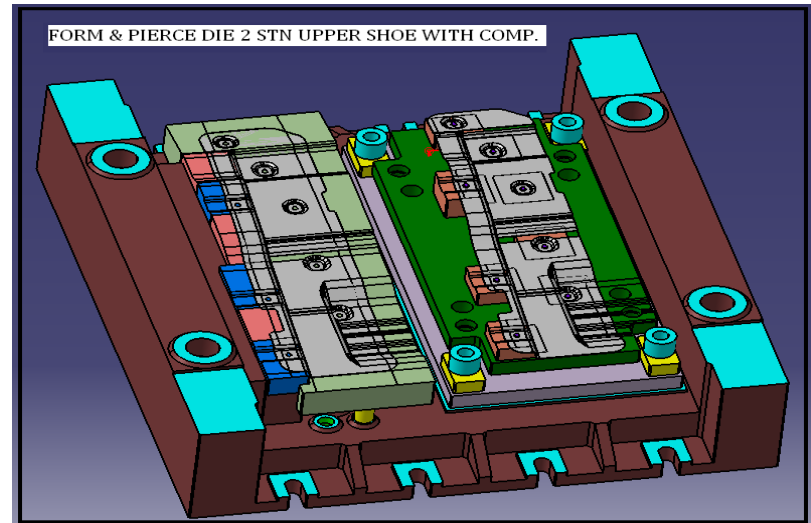
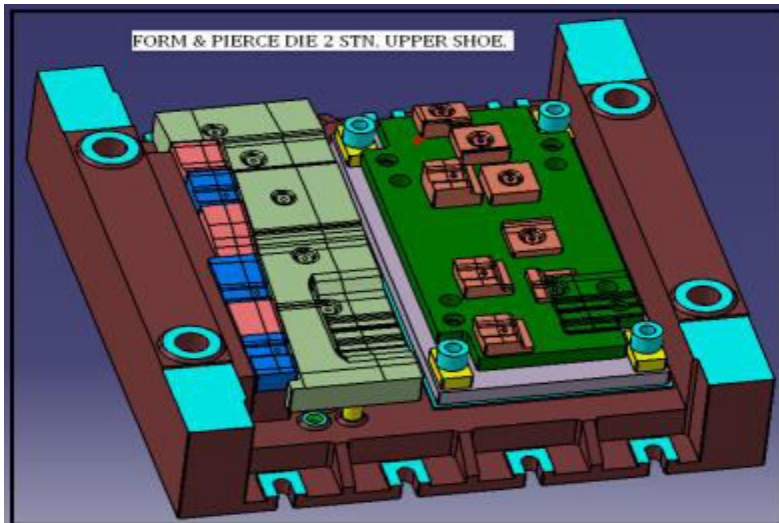
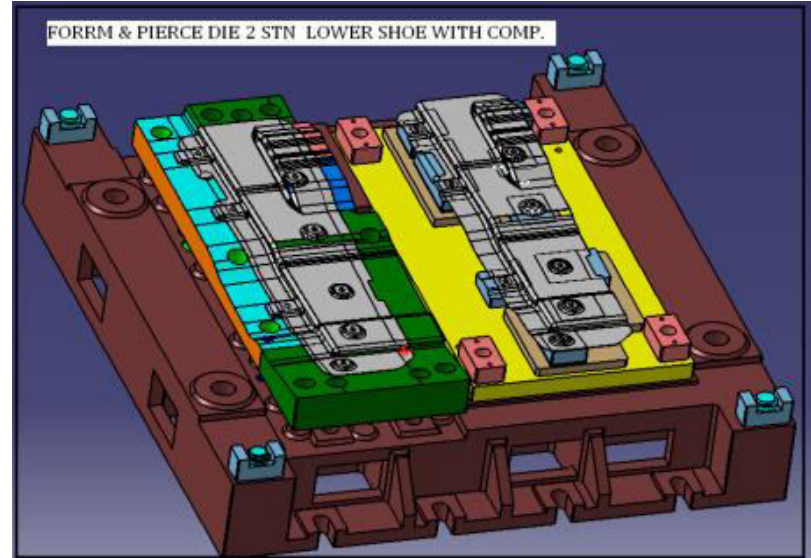
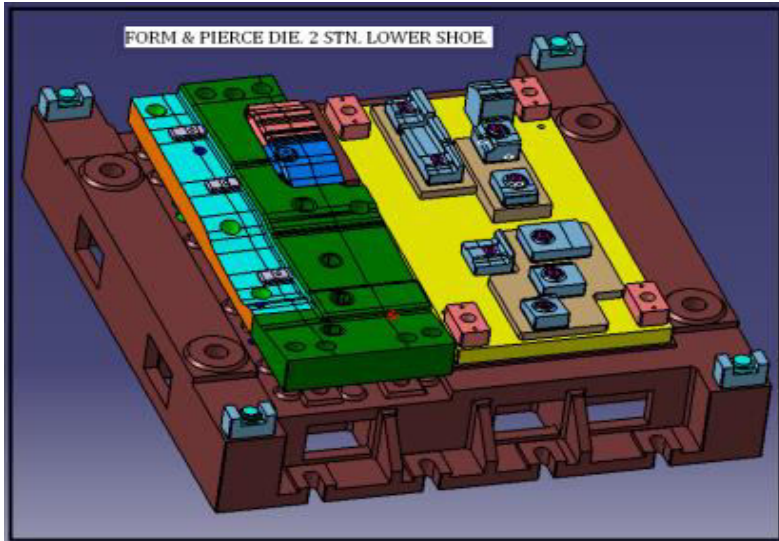

PANNEL CHECKER

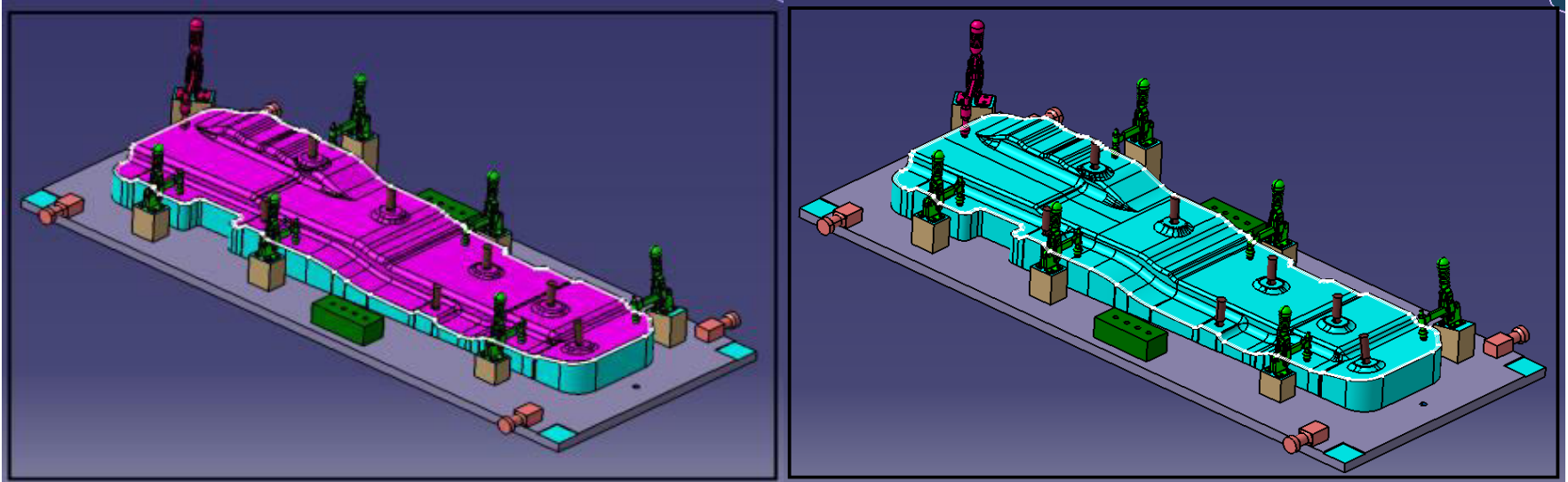

PART NAME:- HEAT SHIELD

MAT:- AL-EN485-2

COMP. SIZE :- 615*615* 225.



OPERATION SEQUENCE:-

| |
|-----------------------------|
| BLANK DIE |
| PRE FORM DIE |
| FORM , TRIM & PIERCE DIE |
| NOTCH DIE |



PRE FORM DIE

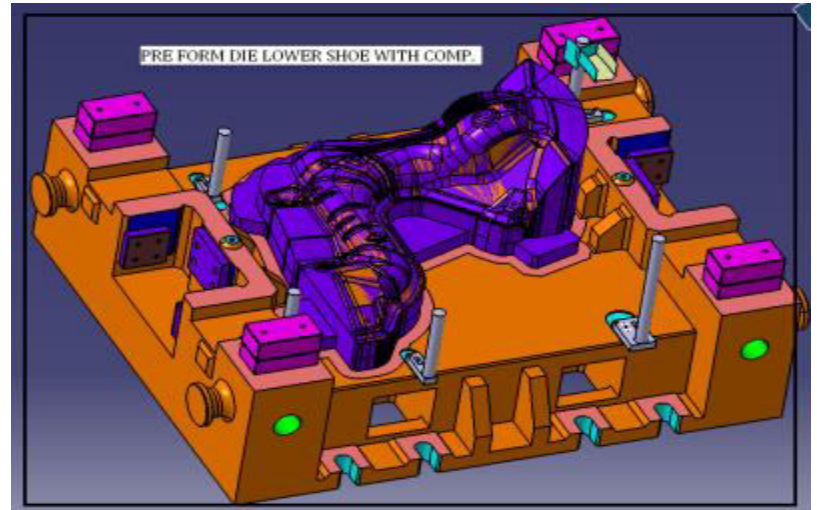
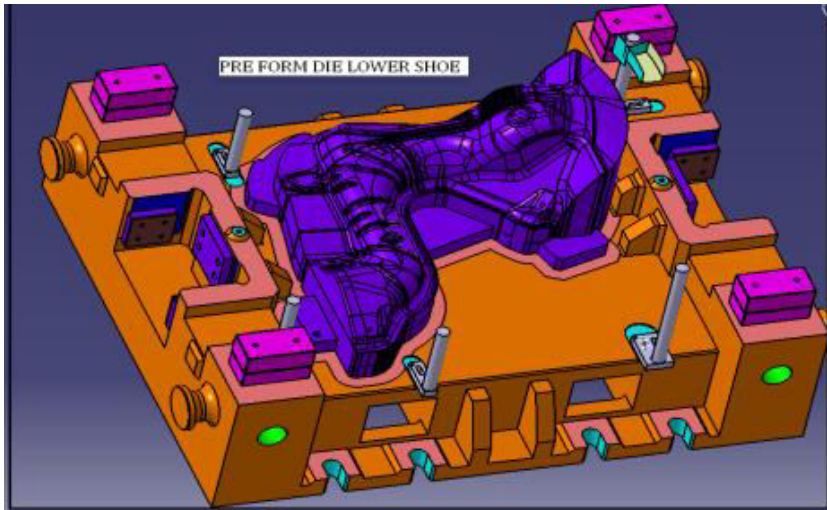

FINAL FORM & TRIM DIE

FORM TRIM DIE LOWER SHOE.

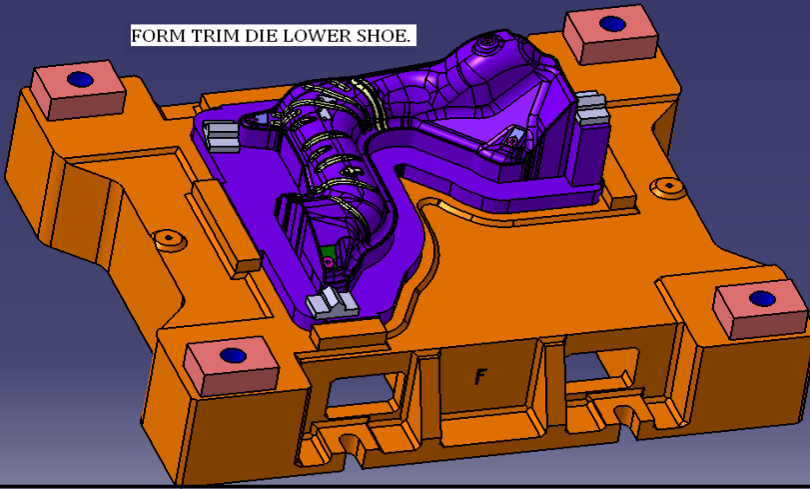

FORM, TRIM DIE LOWER SHOE WITH COMP.

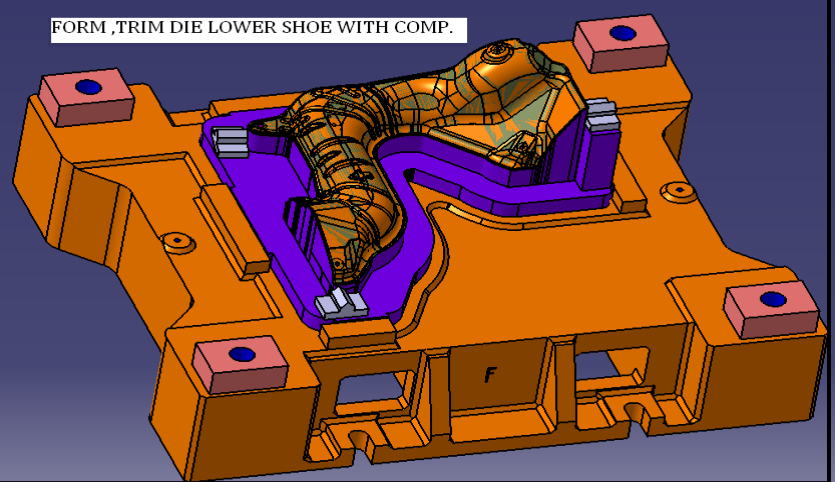

FORM & TRIM DIE LOWER SHOE.

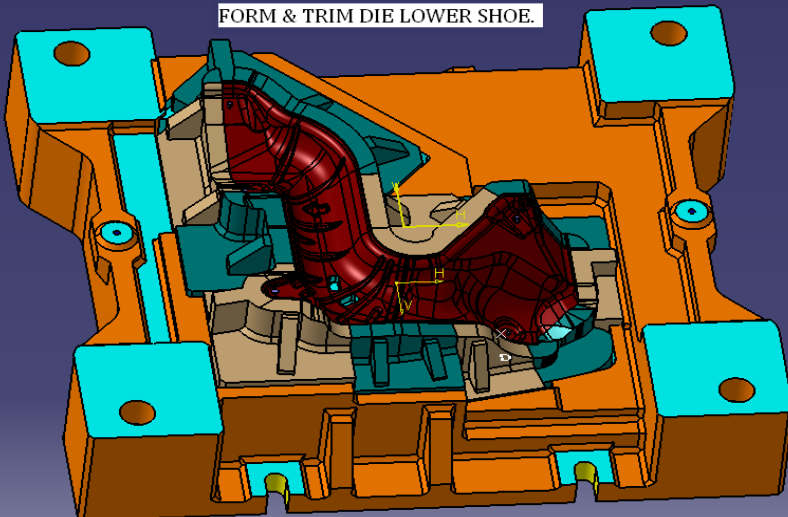

FORM & TRIM DIE UPPER SHOE WITH COMP.

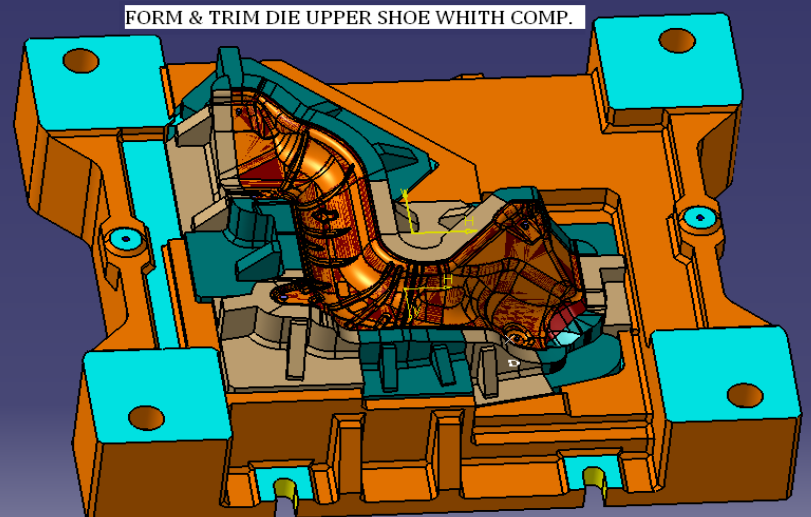

PANNEL CHECKER



PART NAME:- HEAT SHIELD

MAT:- AL-EN485-2 .

COMP. SIZE:- 780*276*198.

OPERATION SEQUENCE

| | |
|----|-------------------------|
| 10 | FORM & TRIM DIE |
| 20 | PIERCE & CAM PIERCE DIE |
| | |
| 10 | PANEL CHECKER |
| | |



FORM & TRIM DIE

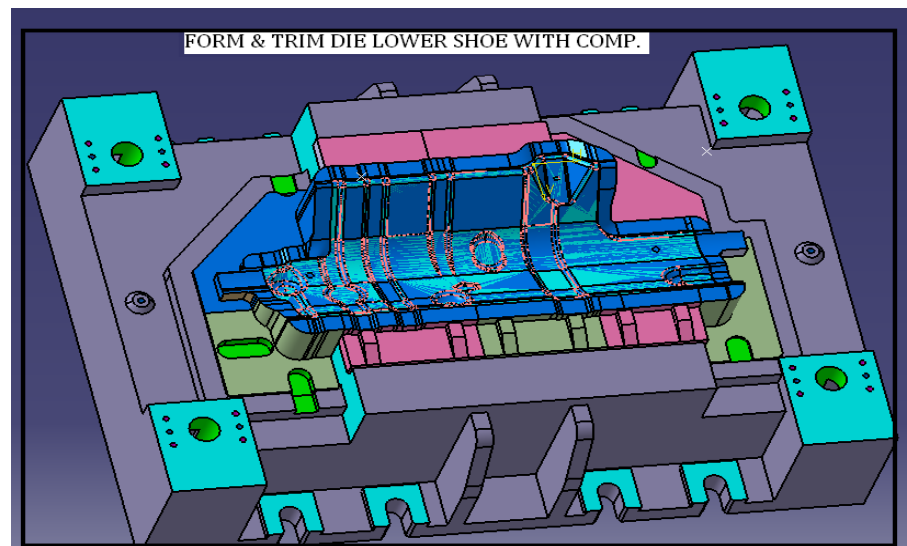
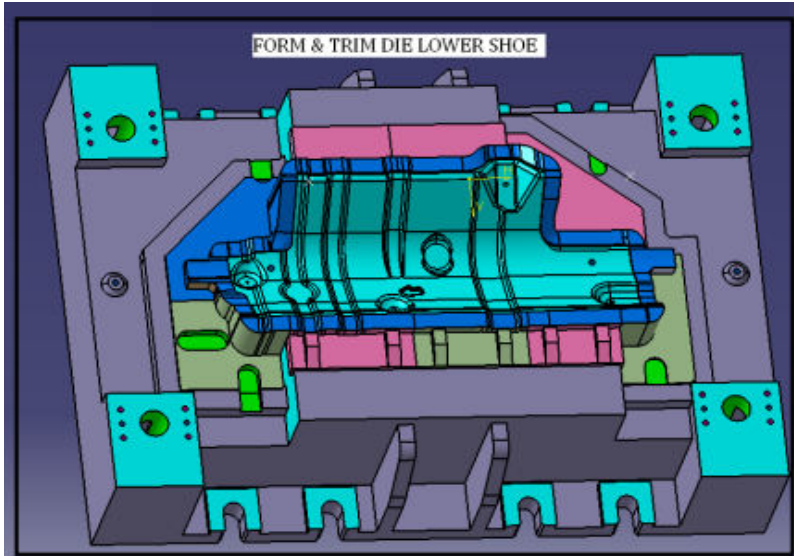
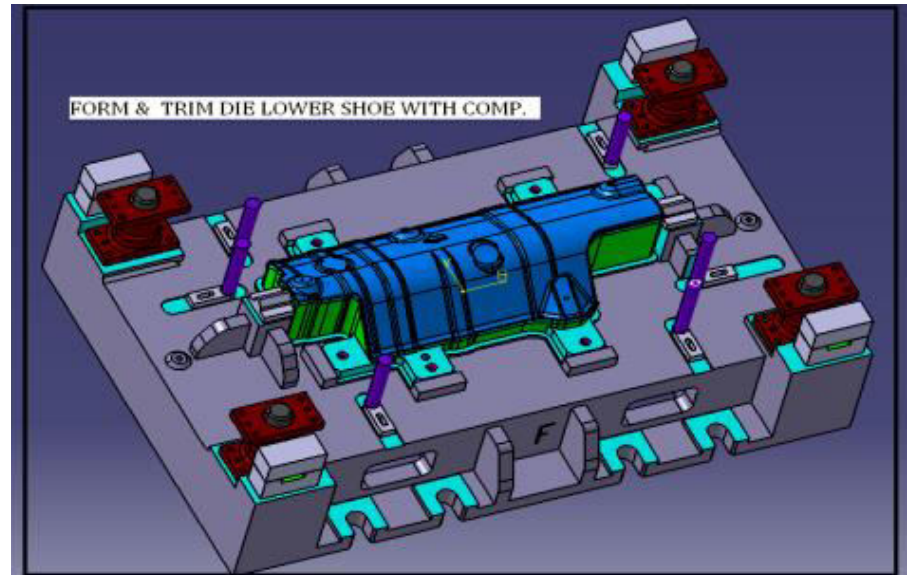
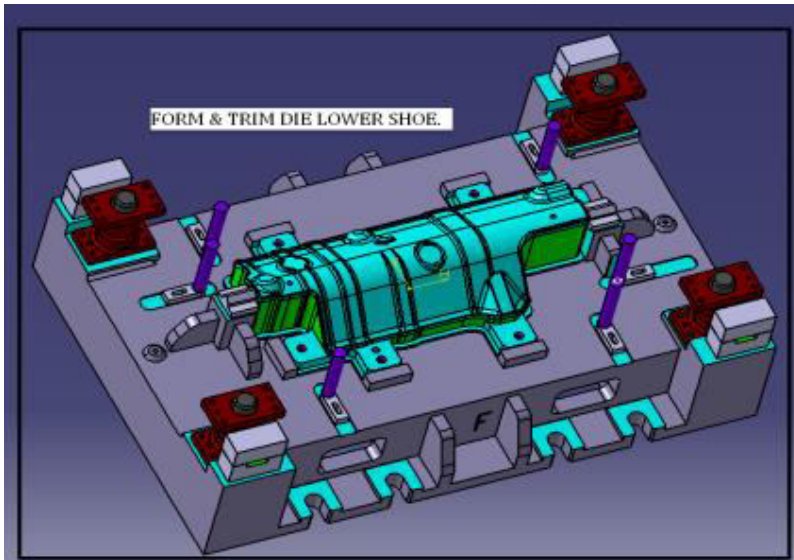

PART NAME :-HEAT SHIELD EXHAUST MANIFLOD

MAT:-SS, AL, Elrotherm 100

COMP. SIZE :- 350*124*102

OPERATION SEQUENCE

| |
|----------------------------|
| BLANK DIE (AL) |
| BLANK DIE (SS) |
| FLANGE DIE (90 DEG) |
| FLANGE DIE (45 DEG) |
| FLATEENING DIE |
| FORM DIE |
| PIERCE DIE (2 STN) |

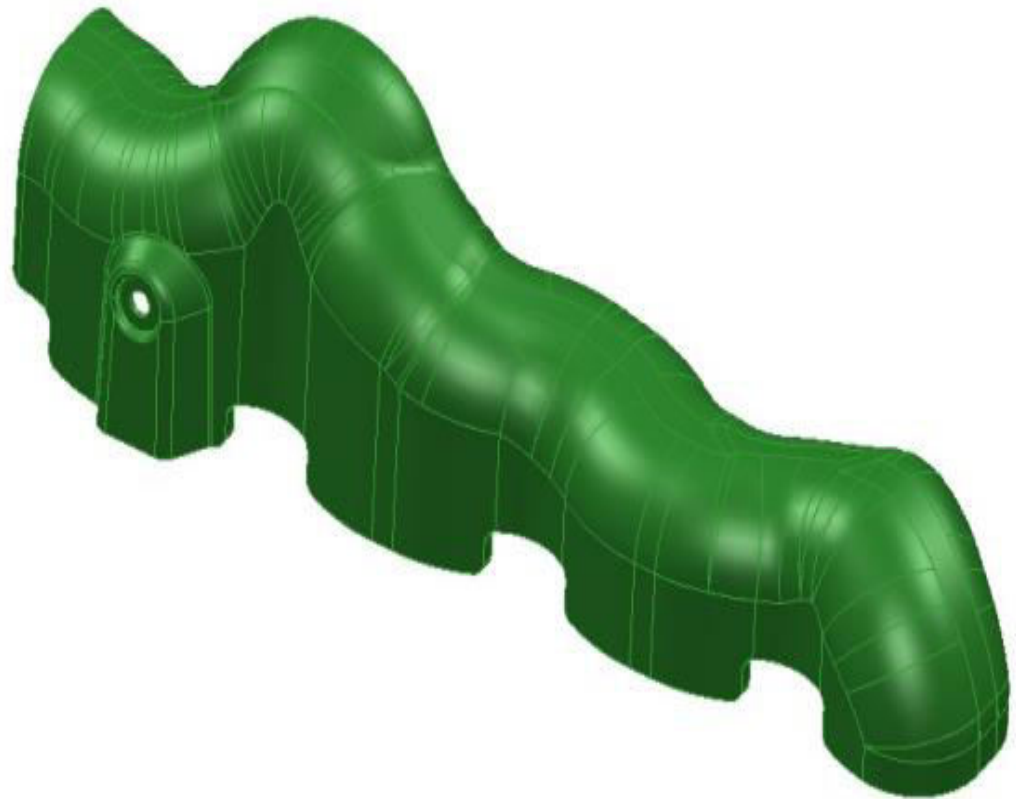

FORM DIE

FORM DIE
LOWER SHOE

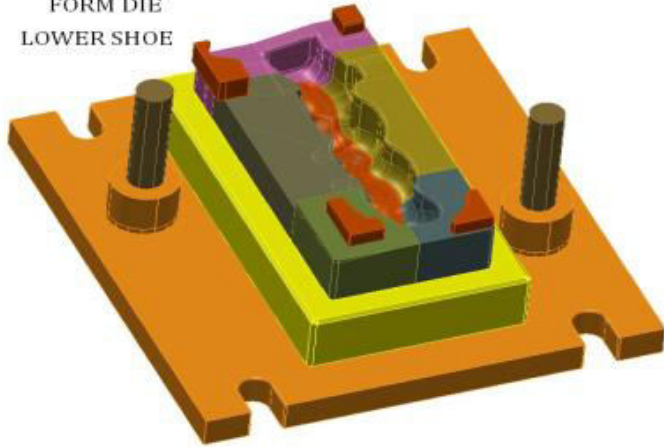

FORM DIE
UPPER SHOE.

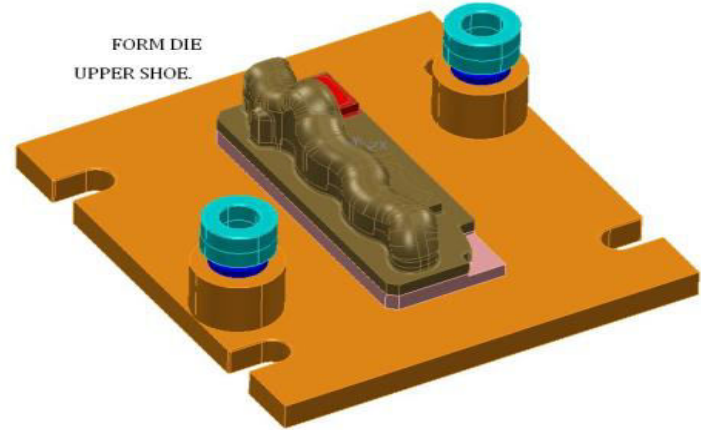

CHECKING FIXTURE

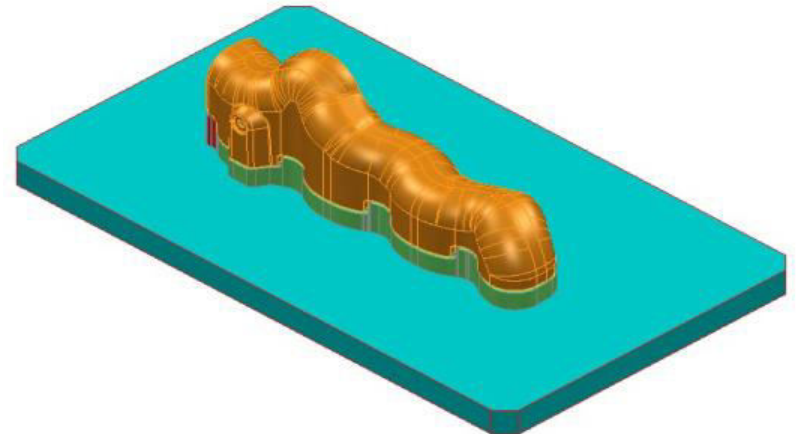
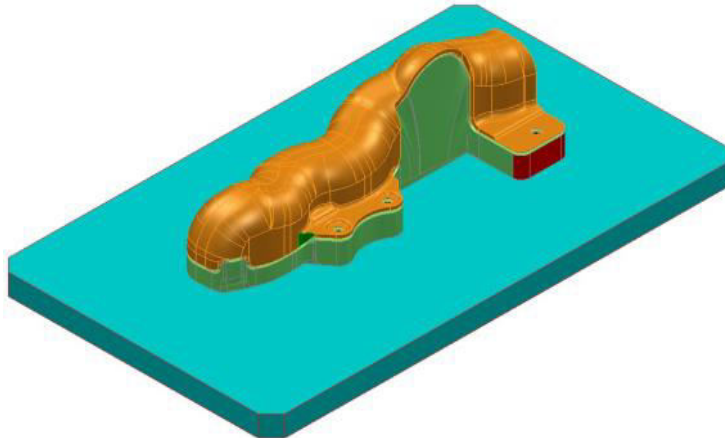

COMP. NAME:- HEAT SHIELD TRUBO CHARGER

MAT:-SS, AL, Elrotherm 100.

COMP. SIZE :- 170*88*76.

OPERATION SEQUENCE

| |
|---------------------|
| BLANK DIE (AL) |
| BLANK DIE (SS) |
| FLANGE DIE (90 DEG) |
| FLANGE DIE (45 DEG) |
| FLATEENING DIE |
| FORM DIE |
| PIERCE DIE (2 STN) |



FORM DIE
LOWER SHOE

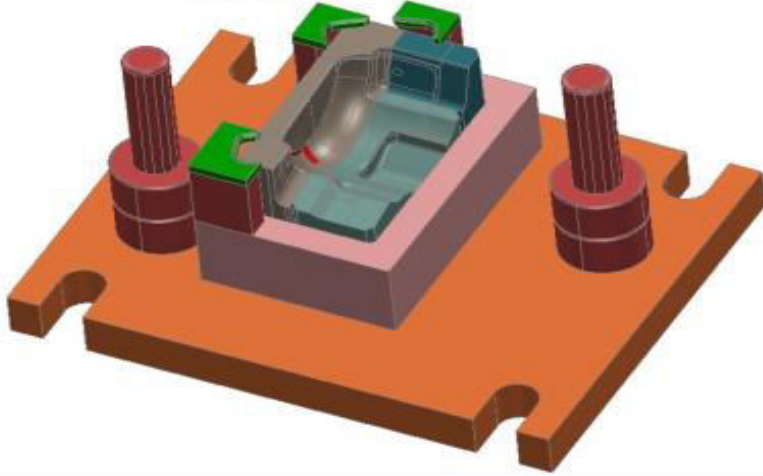

FORM DIE
LOWER SHOE WITH COMP

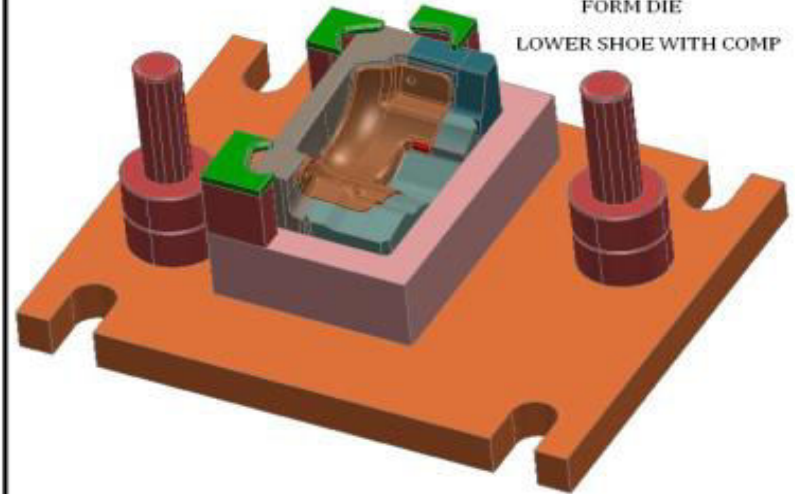

FORM DIE
UPPER SHOE

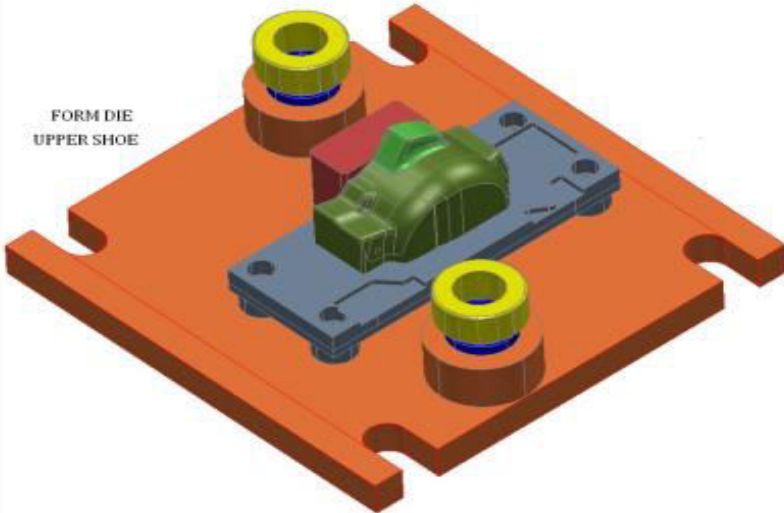

FORM DIE
UPPER SHOE WITH COMP

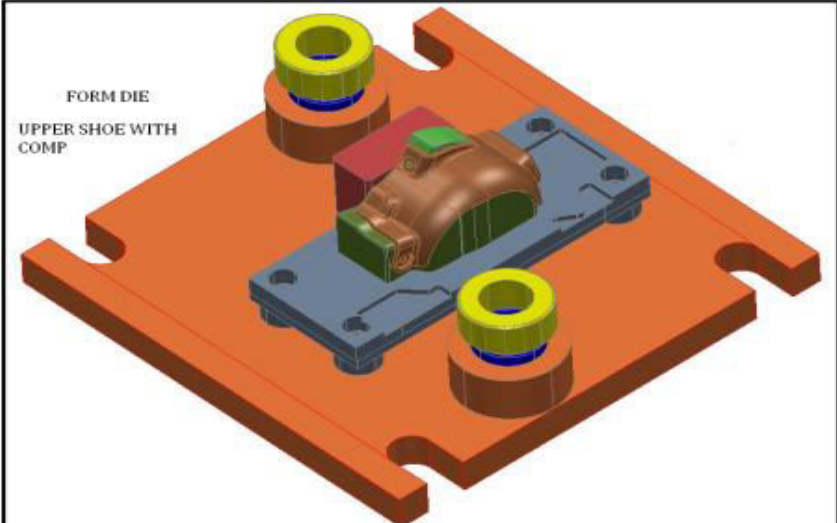

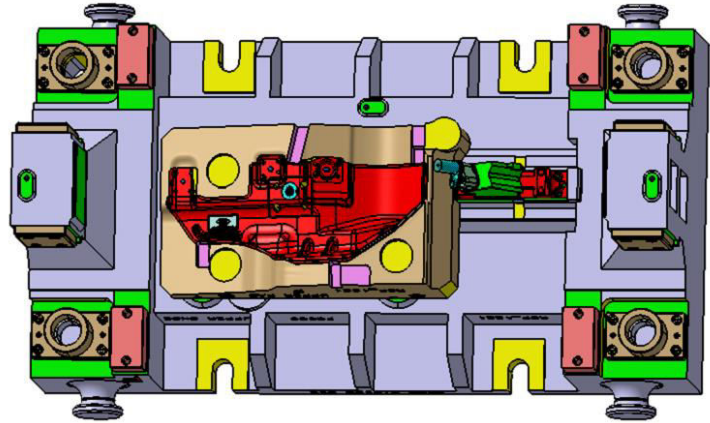
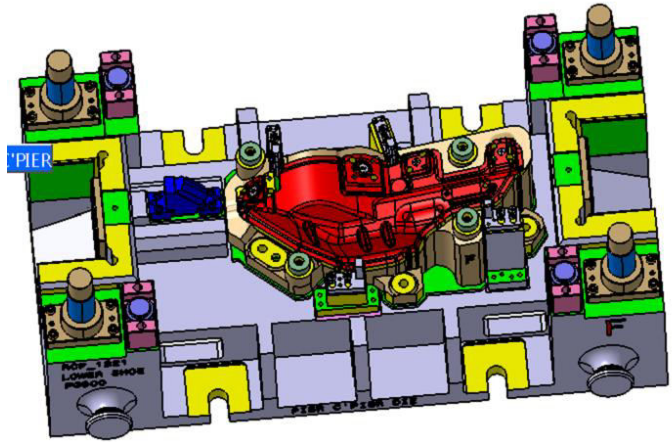
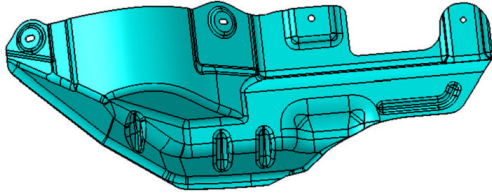

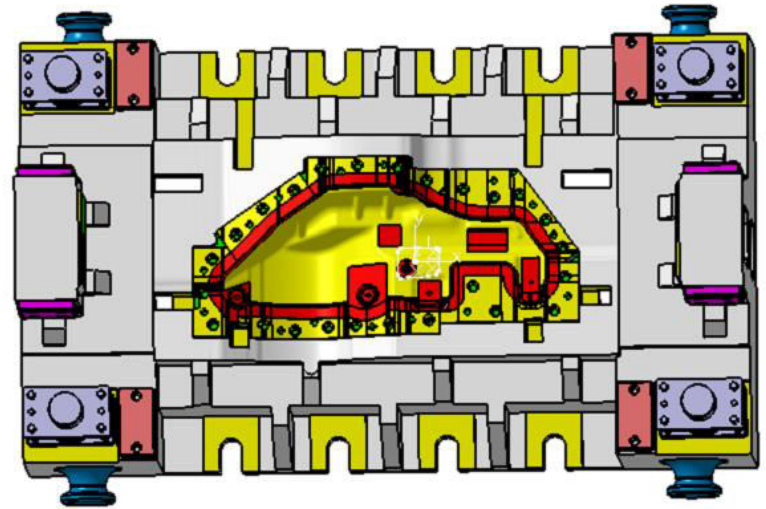
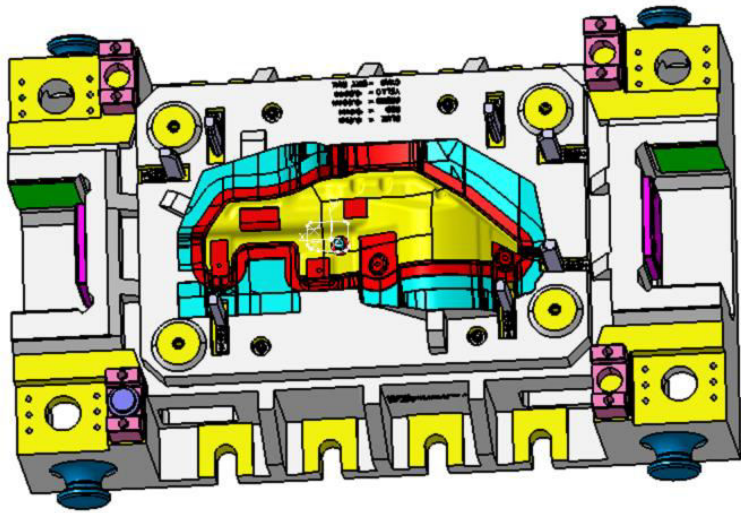
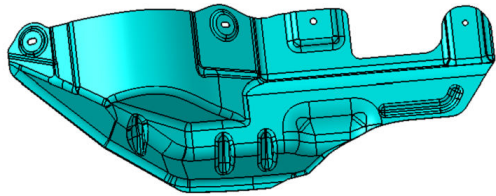

Thank You.....



Address :- Gat No. 255, Opp ' Modern' College,
Behind ' ROSS' Company, Moshi- Dehu Road,
Moshi Pune - 412 105.

Web Site :-www.richcamtooling.com