

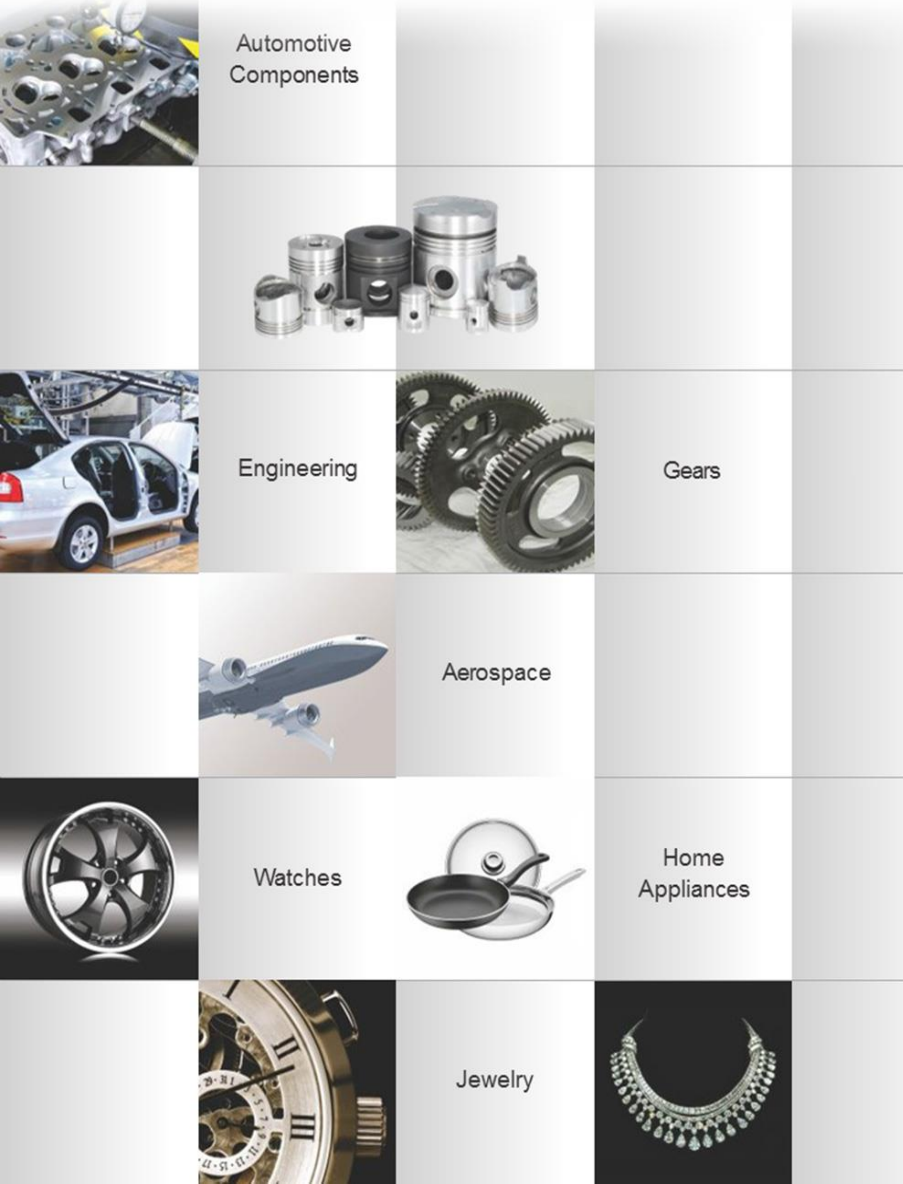

Technical Support with WETECH TOOLS GERMANY



Our Journey...



- 1992 Established Rudrali International for manufacturing natural diamond tools for the Jewelry industry
- 1995 Started manufacturing tools for the Watch industry, and began exporting to Swiss companies
- 1998 Developed specialized diamond tools for silicon wafer cutting applications in the Semiconductor industry
- 2001 Ventured into manufacturing tools for Contact lens cutting and other Ophthalmologic applications
- 2004 Incorporated as Rudrali Hi Tech Tools Pvt. Ltd. and kicked off a phase of rapid expansion and growth
- 2009 We have expanded our range products by acquiring DECOTA Tools Detroit(USA) and entered into PCD/CBN Tools
- 2012 Received the prestigious 'Entrepreneur of the Year Award' from the Government of Maharashtra.
- 2013 Acquired **WETEC** Germany, a 3-decade old German PCD & CBN tools Manufacturing company
- 2015 Established a Manufacturing facility at Pune to cater to major Auto and Engineering OEMs
- 2015 Entered into a strategic technical collaboration with Wetech Tools Germany
- 2016 Separate setup to offer complete solution for Projects with Tooling Package for Automotive/Engineering Industry.

Quality Policy...



CERTIFICATE



Management system as per
EN ISO 9001:2015

In accordance with TÜV AUSTRIA CERT procedures, it is hereby certified that

Rudrali Hitech Tools Pvt. Ltd.

Plot No. 113/7, 'S' Block, MIDC Bhosari, Pune - 411 026, India

applies a management system in line with the above standard for the
following scope

Design, Manufacture and Supply of Cutting Tools

Certificate Registration No. 20100163000848

Valid until 2019-05-12



Certification Body
at TÜV AUSTRIA CERT GMBH

Vienna, 2016-05-13

This certification was conducted in accordance with TÜV AUSTRIA CERT auditing and certification
procedures and is subject to regular surveillance audits.
TÜV AUSTRIA CERT GMBH Krugerstraße 16 A-1015 Wien www.tuv.at



We are committed to full customer satisfaction by manufacturing and supplying of 'Cutting Tools' as per their requirements and schedule.

We have implemented '**Quality Management System – ISO 9001:2015**

We are also implementing following techniques for Enhancing overall quality of our system and products.

**5S,
Kaizen,
Jishu-hozen.**

Infrastructure...



PCD Rotary Tools...



HSK Integral Reamer



HSK Integral Reamer



PCD Milling Cutter



Bell Mouth Type Cutter



BT Integral Reamer



Flange Reamer



Trepanning Tool



OD Profile Tool



Parent Bore Reamer



Spherical Dom Profile Cutter

PCD/CBN Special Tools



PCD/CBN Inserts



Natural Diamond Tools



Milling Cutter



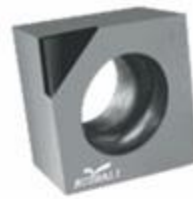

CCMW 09T304



SNEW 1204 ADFR



TNMA 160404

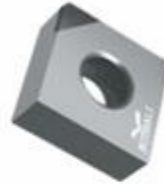

CNMA 120404



VCGT 160404



RNGN 1204

PCD Inserts...



Applications for PCD Tools

Automotive

Cylinder Head, Cylinder Block, Transmission Housing, Crank Case, Steering Housing, Master Cylinders, Valve Bodies, Throttle Bodies, Carburetors, Fuel Pumps, Oil Pumps Bodies, Air Conditioning Compressors & Housings, Starter Motor Housing, Pistons & Alloy Wheels.

Pumps/Valves

Housings, Moving Parts

Defence Sector

Brass Parts

Home Appliances

Home Utensils

Aircraft / Aerospace

Wing Tips, Ducts, Floor Posts, Cowling, Structural Components, Trim Panels

Electrical Machinery

Commutator Shafts / Housings

Computer & Electronic

Moving Discs, Mirrors/Lenses.

CBN Inserts...

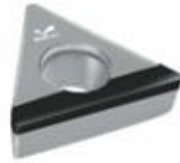

FE TCMW 110204



3NU TCMW 110204

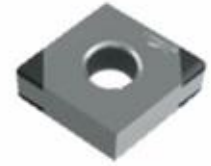

4NU CNMA 120404



2NU SNGA 120404



2NU VNGA 160408



SOLID CBN



Applications for CBN Tools

Automotive

Gears, Axles, Shafts, Bearings, Engine Blocks, Valve Seats, Brake Rotors, Brake Drums, Clutch Plates, Transfer Housings

Aircraft / Aerospace

Combustion Case, Shafts, Landing Gear, Bolts, Struts, Cylinders, Turbine Disk, Turbine Blades, Turbine, Shrouds, Engine Shafts, Turbine Vanes

Engineering

Steel Roller

Other

Pumps, Impellers, Shafts.

Carbide Tools...



Special Tools

Boring Tools, Woodruff Cutters, Form Cutters ,
T- Slot Cutters, Hole Mills, Countersinks,
Counter Bores, Corner Radius Cutters

Ball Nose

Ball Nose Milling Cutter, Shoulder Milling Cutter,
Rough Milling Cutter, Semi Finish Milling Cutter,
Finish Milling Cutter, Slot Milling Cutter,
Burr Milling Cutter

Drills

Gun Drills, Centre Drills, Step Drills, Long Drills,
3-Flute Drills, Twist Drills, Burnishing Drills,
Flat Bottom Drills, Micro Drills, Spotting Drills, Through
Coolant Drills, Spade Drills

Reamers

Micro Reamers, Multi Diameter Reamers, Solid Reamers ,
Taper Reamers ,Gun Reamers, Extra Long Reamers,
Through Coolant Reamers, Burnishing Reamers

Customized Tools as per Application...

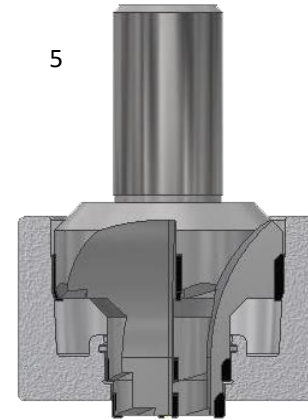
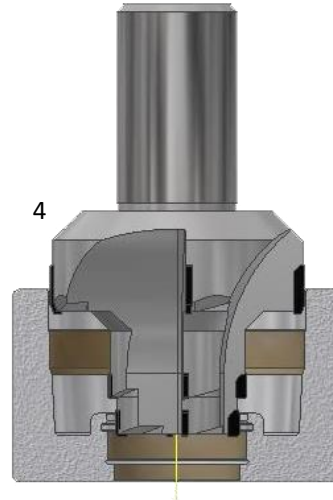
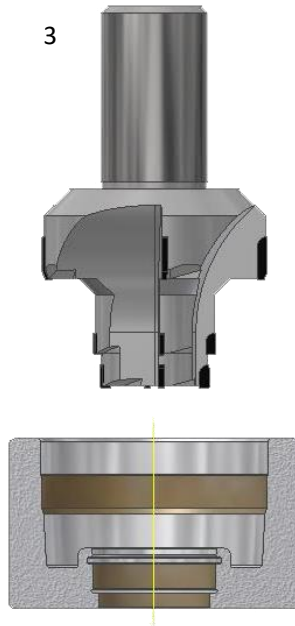
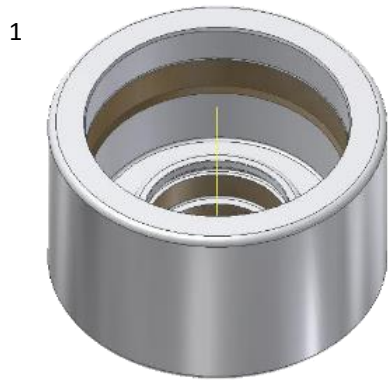

Solutions for Automotive Industry...

Cylinder Head Machining

Milling Solutions...



Cast Iron Machining



Brazed Milling Cutter



Aluminum Machining



Cylinder Block



Cylinder Head

Valve Seat & Valve Guide Machining...



Cylinder Head



Valve Guide Reamer

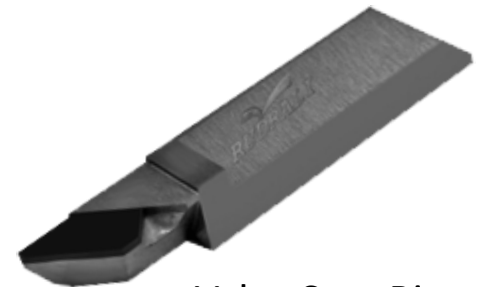

Valve Seat Bite

Cyl. Head & Block Machining...



PCD/CBN Tools

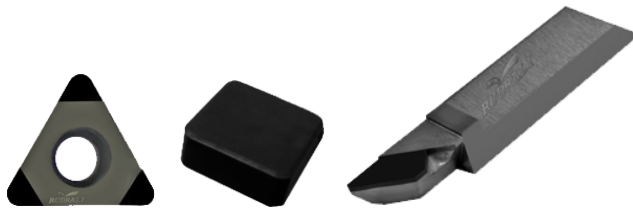

4W Cyl. Block



4W Cyl. Head



2W Cyl. Head



Cr. Case & Trsm. Housing Machining...

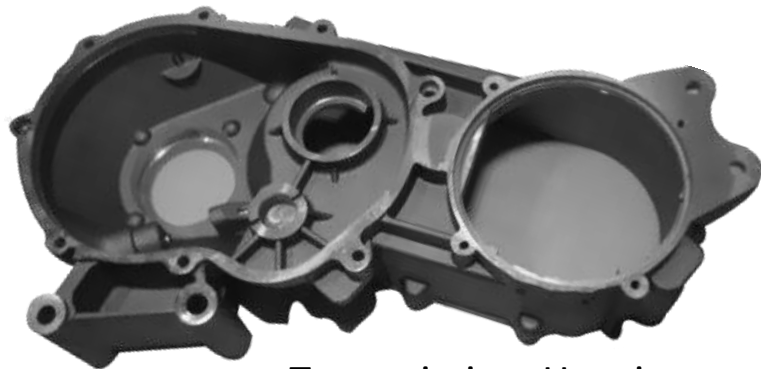

Transmission Housing

PCD Reamers

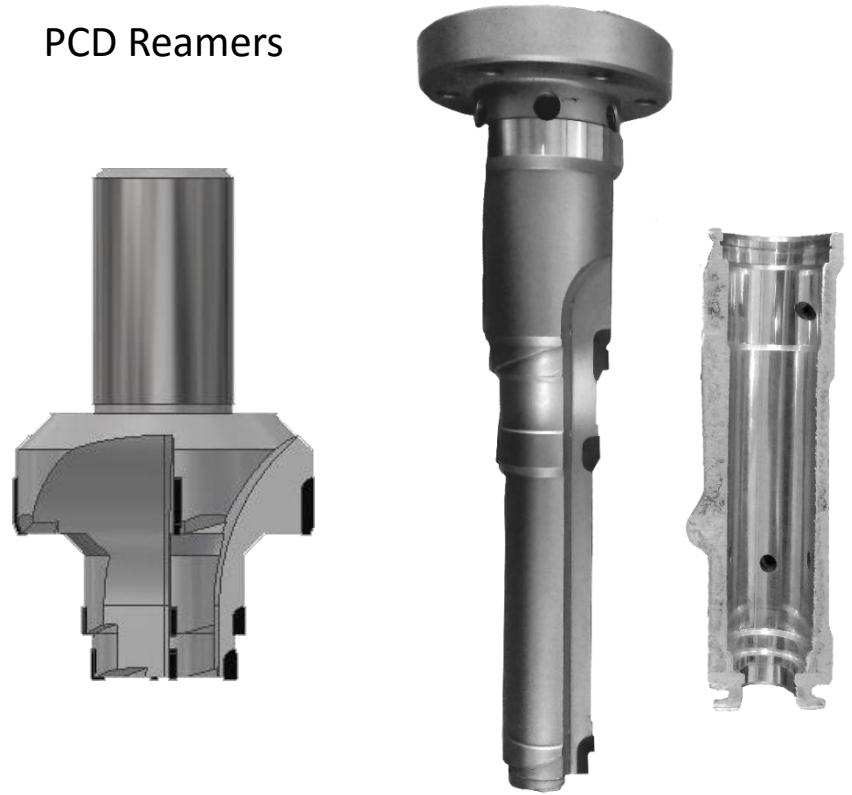

Natural Diamond Tools...



POSALUX TOOL



CNC TOOL



ICE LATH TOOL



PCD TOOL



FLY CUTTER



VACUUM BRASED TOOL



Applications of Natural Diamond Tools

Jewelry

Platinum, Gold & Silver Jewelry,
Fashion Jewelry, CNC Cutting & Engraving

Diamond

Diamond Sawing

Computer Hardware

Silicon Wafer Cutting

Ophthalmology

Contact Lens, Surgery Tools

Electrical Motors

DC motor Commutator

Automobile

Wheel Dressing

Engineering

Wire Drawing, CNC Milling.

Watch

Watch Parts

Overseas Customers...





Indian Customers...



Customer's Rating...

Ven-tech Pvt. Ltd.

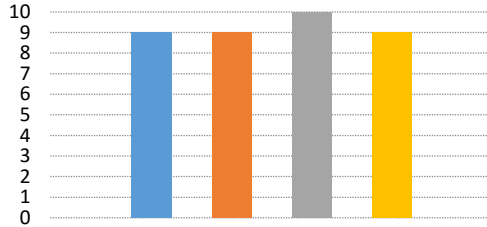



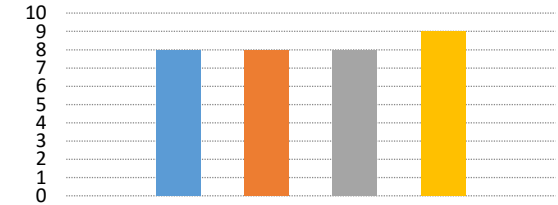

■ Quality ■ Delivery
■ Service ■ Communication

Sigma Electric Manufacturing Corporation Pvt. Ltd.



■ Quality ■ Delivery
■ Service ■ Communication

 Rudrali Hitech Tools Pvt. Ltd.	CUSTOMER FEEDBACK FORM	Format No.: F-7205 Revision No.: 01 Revision Date: 26.08.2008 Issue No./Date: 01 / 01.04.2007
YEAR: 2015-16 CUSTOMER NAME: ventech Pvt Ltd.		
❖ QUALITY: 1) PUT YOUR RATING FOR OUR PRODUCT QUALITY:		
<input type="checkbox"/> 1 <input type="checkbox"/> 2 <input type="checkbox"/> 3 <input type="checkbox"/> 4 <input type="checkbox"/> 5 Poor	<input type="checkbox"/> 6 <input type="checkbox"/> 7 <input type="checkbox"/> 8 Good	<input checked="" type="checkbox"/> 9 <input type="checkbox"/> 10 Excellent
		Rating: 9
❖ DELIVERY: WHETHER YOUR ORDER WAS COMPLETED WITHIN TIME? YES / NO IF NO PLEASE MENTION DELAYED NO. OF DELIVERIES.		
<input checked="" type="checkbox"/> YES / <input type="checkbox"/> NO		
2) PUT YOUR RATING FOR OUR DELIVERY PERFORMANCE:		
<input type="checkbox"/> 1 <input type="checkbox"/> 2 <input type="checkbox"/> 3 <input type="checkbox"/> 4 <input type="checkbox"/> 5 Poor	<input type="checkbox"/> 6 <input type="checkbox"/> 7 <input type="checkbox"/> 8 Good	<input checked="" type="checkbox"/> 9 <input type="checkbox"/> 10 Excellent
		Rating: 9
❖ SERVICE: 3) PUT YOUR RATING FOR OUR QUALITY OF PAPER WORKS & PACKING:		
<input type="checkbox"/> 1 <input type="checkbox"/> 2 <input type="checkbox"/> 3 <input type="checkbox"/> 4 <input type="checkbox"/> 5 Poor	<input type="checkbox"/> 6 <input type="checkbox"/> 7 <input type="checkbox"/> 8 Good	<input checked="" type="checkbox"/> 9 <input type="checkbox"/> 10 Excellent
		Rating: 10
4) PUT YOUR RATING FOR OUR RESPONSE TO COMMUNICATION:		
<input type="checkbox"/> 1 <input type="checkbox"/> 2 <input type="checkbox"/> 3 <input type="checkbox"/> 4 <input type="checkbox"/> 5 Poor	<input type="checkbox"/> 6 <input type="checkbox"/> 7 <input type="checkbox"/> 8 Good	<input checked="" type="checkbox"/> 9 <input type="checkbox"/> 10 Excellent
		Rating: 9
ANY SUGGESTION / COMPLAINTS:		
 CUSTOMER SIGN & STAMP		

 Rudrali Hitech Tools Pvt. Ltd.	CUSTOMER FEEDBACK FORM	Format No.: F-7205 Revision No.: 01 Revision Date: 26.08.2008 Issue No./Date: 01 / 01.04.2007
YEAR: 2015-16 CUSTOMER NAME: sigma ele mfg corp (p) Ltd		
❖ QUALITY: 1) PUT YOUR RATING FOR OUR PRODUCT QUALITY:		
<input type="checkbox"/> 1 <input type="checkbox"/> 2 <input type="checkbox"/> 3 <input type="checkbox"/> 4 <input type="checkbox"/> 5 Poor	<input checked="" type="checkbox"/> 6 <input type="checkbox"/> 7 <input type="checkbox"/> 8 Good	<input type="checkbox"/> 9 <input type="checkbox"/> 10 Excellent
		Rating: 6.5/8
❖ DELIVERY: WHETHER YOUR ORDER WAS COMPLETED WITHIN TIME? YES / NO IF NO PLEASE MENTION DELAYED NO. OF DELIVERIES.		
<input checked="" type="checkbox"/> YES / <input type="checkbox"/> NO		
2) PUT YOUR RATING FOR OUR DELIVERY PERFORMANCE:		
<input type="checkbox"/> 1 <input type="checkbox"/> 2 <input type="checkbox"/> 3 <input type="checkbox"/> 4 <input type="checkbox"/> 5 Poor	<input checked="" type="checkbox"/> 6 <input type="checkbox"/> 7 <input type="checkbox"/> 8 Good	<input type="checkbox"/> 9 <input type="checkbox"/> 10 Excellent
		Rating: 8
❖ SERVICE: 3) PUT YOUR RATING FOR OUR QUALITY OF PAPER WORKS & PACKING:		
<input type="checkbox"/> 1 <input type="checkbox"/> 2 <input type="checkbox"/> 3 <input type="checkbox"/> 4 <input type="checkbox"/> 5 Poor	<input checked="" type="checkbox"/> 6 <input type="checkbox"/> 7 <input type="checkbox"/> 8 Good	<input type="checkbox"/> 9 <input type="checkbox"/> 10 Excellent
		Rating: 8
4) PUT YOUR RATING FOR OUR RESPONSE TO COMMUNICATION:		
<input type="checkbox"/> 1 <input type="checkbox"/> 2 <input type="checkbox"/> 3 <input type="checkbox"/> 4 <input type="checkbox"/> 5 Poor	<input type="checkbox"/> 6 <input type="checkbox"/> 7 <input type="checkbox"/> 8 Good	<input checked="" type="checkbox"/> 9 <input type="checkbox"/> 10 Excellent
		Rating: 8.5/9
ANY SUGGESTION / COMPLAINTS: Need to improve webly system to PCD reamer like flange (compensative widder)		
 CUSTOMER SIGN & STAMP		

Customer's Rating...



Endurance Technologies Ltd.

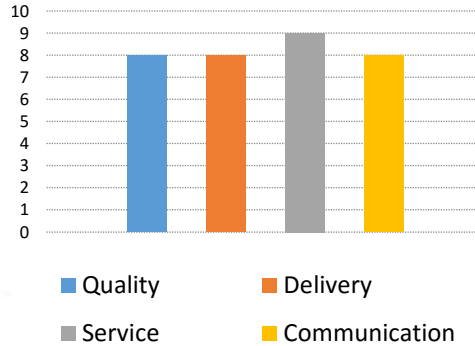

Kiran Udog Pvt. Ltd.

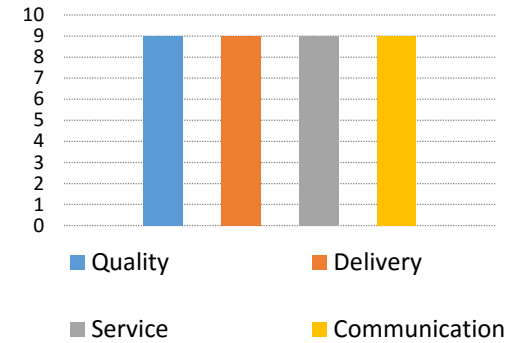

CUSTOMER FEEDBACK FORM		Format No.: F-7205
		Revision No.: 01
		Revision Date: 18.02.2015
		Issue No./Date: 01 / 01.04.2007
YEAR :2015-2016		
CUSTOMER NAME: <i>Endurance Technologies Pvt Ltd.</i>		
❖ QUALITY:		
1) PUT YOUR RATING FOR OUR PRODUCT QUALITY:		
1 2 3 4 5 Poor	6 7 8 Good	9 10 Excellent
		Rating <i>8</i>
❖ DELIVERY:		
WHETHER YOUR ORDER WAS COMPLETED WITHIN TIME? <input checked="" type="checkbox"/> YES / <input type="checkbox"/> NO IF NO PLEASE MENTION DELAYED NO. OF DELIVERIES.		
2) PUT YOUR RATING FOR OUR DELIVERY PERFORMANCE:		
1 2 3 4 5 Poor	6 7 8 Good	9 10 Excellent
		Rating <i>8</i>
❖ SERVICE:		
3) PUT YOUR RATING FOR OUR QUALITY OF PAPER WORKS & PACKING:		
1 2 3 4 5 Poor	6 7 8 Good	9 10 Excellent
		Rating <i>9</i>
4) PUT YOUR RATING FOR OUR RESPONSE TO COMMUNICATION:		
1 2 3 4 5 Poor	6 7 8 Good	9 10 Excellent
		Rating <i>8</i>
ANY SUGGESTION / COMPLAINTS :		
<i>Please Plan more visit of Technical Team to improve product quality & Enhance business opportunity.</i>		
ENDURANCE TECHNOLOGIES PVT. LTD. Plot No. B-20, Chakan Industrial Area, Village Nighegaon, Tal. Khed, Pune-410 501. (M.S.) India CUSTOMER SIGN & STAMP		

CUSTOMER FEEDBACK FORM		Format No.: F-7205
		Revision No.: 01
		Revision Date: 18.02.2015
		Issue No./Date: 01 / 01.04.2007
YEAR :2015-2016		
CUSTOMER NAME: <i>Kiran Udog Pvt. Ltd.</i>		
❖ QUALITY:		
1) PUT YOUR RATING FOR OUR PRODUCT QUALITY:		
1 2 3 4 5 Poor	6 7 8 Good	9 10 Excellent
		Rating <i>9</i>
❖ DELIVERY:		
WHETHER YOUR ORDER WAS COMPLETED WITHIN TIME? <input checked="" type="checkbox"/> YES / <input type="checkbox"/> NO IF NO PLEASE MENTION DELAYED NO. OF DELIVERIES.		
2) PUT YOUR RATING FOR OUR DELIVERY PERFORMANCE:		
1 2 3 4 5 Poor	6 7 8 Good	9 10 Excellent
		Rating <i>9</i>
❖ SERVICE:		
3) PUT YOUR RATING FOR OUR QUALITY OF PAPER WORKS & PACKING:		
1 2 3 4 5 Poor	6 7 8 Good	9 10 Excellent
		Rating <i>9</i>
4) PUT YOUR RATING FOR OUR RESPONSE TO COMMUNICATION:		
1 2 3 4 5 Poor	6 7 8 Good	9 10 Excellent
		Rating <i>9</i>
ANY SUGGESTION / COMPLAINTS :		
KIRAN UDOG PVT. LTD. CUSTOMER SIGN & STAMP		

Milling operation for Oil pump housing of the **Ford Motors** done by RUDRALI at KSPG
With Integrated milling cutter tool and get the following results against
German competitor:

Trial Tool	→	Ø40 Milling Cutter
Component	→	Oil Pump Housing (Ford)
Material	→	Aluminum (Si-11%)
Machine	→	Makino a51
Machine Type	→	HMC



Face and Side wall Milling

RUDRALI		COMPETITOR	
CUTTING SPEED	942 m/min	CUTTING SPEED	800 m/min
RPM	7500	RPM	6370
FEED	3500 mm/min	FEED	3000 mm/min
LIFE	50000	LIFE	33000
ROUGHNESS	0.15	ROUGHNESS	0.2
CYCLE TIME	171 sec.	CYCLE TIME	200 sec.



	Rudrali	Competitor
Tool Life	50000	33000
Tool Cost	70000	80000
Component mfg./day	270	270
CPC	1.4	2.42
Cost Saving yearly due to cycle time	6.75 lacks	
Cost saving due to tool performance and cost	0.83 lacks	
Total Saving yearly / Machine	7.58 lacks	

Reaming operation for Crank Case Right done by RUDRALI PCD Reamer and achieved following results against German competitor:

Trial Tool	→	Ø12 PCD Reamer
Component	→	CCR Module
Material	→	Aluminum (Si-11%)
Machine	→	Fanuc Robo-Drill



RUDRALI		COMPETITOR	
CUTTING SPEED	180 m/min	CUTTING SPEED	180 m/min
RPM	4777	RPM	4777
FEED	1500 mm/min	FEED	1500 mm/min
LIFE	500000	LIFE	200000
ROUGHNESS	0.56	ROUGHNESS	0.7
CYCLE TIME	15 sec.	CYCLE TIME	15 sec.



	Rudrali	Competitor
Tool Life	500000	200000
Tool Cost	16500	20000
CPC	0.033	0.1
Saving/Component	0.06	
Yearly Saving/Machine	0.67 Lacks	

Life comparison

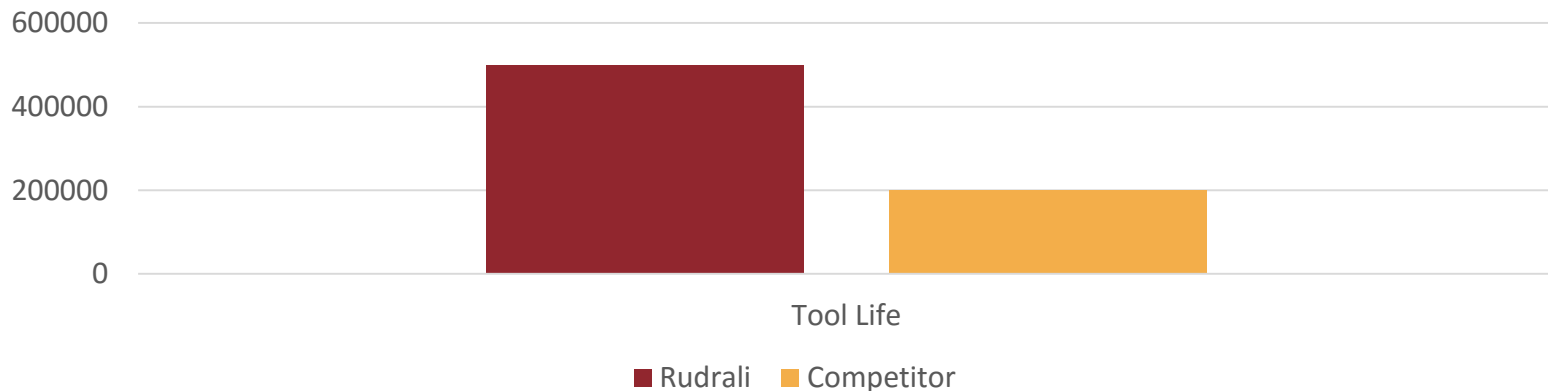

Finishing operation for Valve Seat Ring of the **Bajaj Auto Ltd.** done by RUDRALI with VSR CBN Bite and achieved following results against Japanese competitor:

Trial Tool	→	90 ° VSR Bite
Component	→	Cylinder Head
Material	→	Sintered steel
Machine	→	MTD



RUDRALI		COMPETITOR	
CUTTING SPEED		CUTTING SPEED	m/min
RPM	623	RPM	623
FEED	40 mm/min	FEED	40 mm/min
LIFE	10220	LIFE	8000
CYCLE TIME	30 sec.	CYCLE TIME	30 sec.



	Rudrali	Competitor
Tool Life	10220	8000
Tool Cost	2500	3000
CPC	0.25	0.38
Saving/Component	0.52	

Life comparison

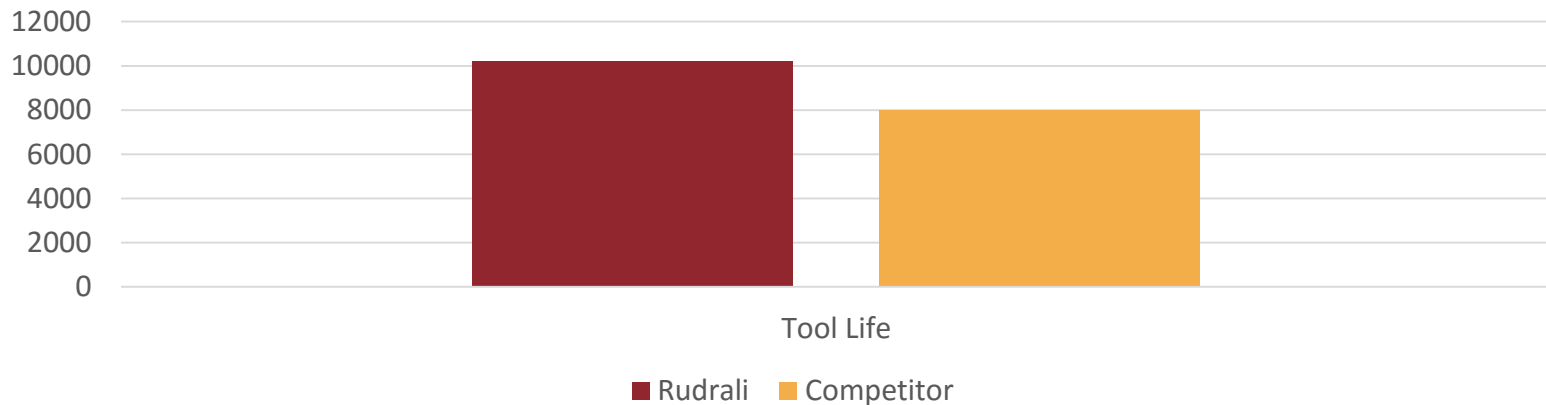

Success Stories at C-Tech Engg. ...

ID Boring operation for Hard Bush of **Hyundai Motors Ltd.** done by RUDRALI at C-Tech Engg. with CBN insert and achieved following results against Swedish competitor:

Trial Tool	➔	2NU CNGA 120408 RHB 313
Component	➔	Bush
Material	➔	Hardened Steel (SCM 415)
Machine	➔	Mazak Quick Turn Smart 150 S
Hardness		58-60 HRC



Interrupted ID boring

RUDRALI		COMPETITOR	
CUTTING SPEED	67 m/min	CUTTING SPEED	67 m/min
RPM	270	RPM	270
FEED	0.2 mm/rev	FEED	0.15 mm/rev
LIFE	200	LIFE	120
CYCLE TIME	2.5 min	CYCLE TIME	3 min



Cost Saving to C-Tech Engg...

	Rudrali	Competitor
Tool Life	200	120
Tool Cost	2300	3000
CPC	11.5	25
Saving/Component	13.5	
Yearly Saving /Machine	3.24 Lacks	

Life comparison

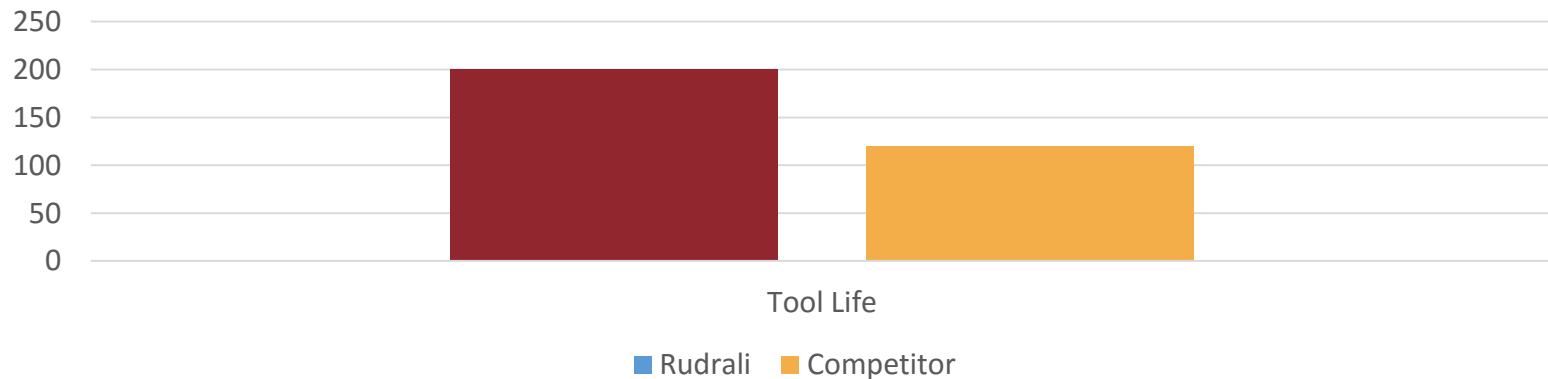

Tool Management Services...

RUDRALI TOOL MANAGEMENT SERVICES is a division of Rudrali Hi Tech Tools Pvt. Ltd.:-

At RTMS (Rudrali Tool Management services) We provide the VALUE ADDED SERVICES to the customers RTMS has a separate set-up for it's uninterrupted services to their esteemed customers for optimum utilization of tools.

TOOL RESHARPENING:-

At RTMS we do the re-sharpening of Diamond, PCD & CBN tools on special Machines mostly are from Switzerland & Germany, On our imported machines we get BEST QUALITY OF SHARPENED EDGE to achieve the optimum tool life which is certainly cost effective & reduces the tool cost per piece in the present cut throat competitive Indian market.

RE-CONDITIONING / RE-TIPPING OF THE TOOL:

Our Reconditioning facility has ultra precision Swiss machines and German High Vacuum brazing furnace. We recondition the worn-out tools from the customers by Re-tipping and Re-sharpening, We Recondition old tools as good as New Tool. The tools reconditioned by us will give the same results as new tool. We also Recondition worn out tool/Insert and convert them for other application.

Turn Key Projects...



Turnkey solution for new projects Tooling's:-

At Rudrali we have a highly experienced and professionals Design, Engineering & Application Team. This cluster of experienced professionals have successfully implemented new turnkey projects for automobile components & other engineering products. At Rudrali we also under take the productivity improvement projects as value added service through process, tools & program modification over existing set-up with cost effective solutions.



Rudrali Network...

Corporate Sales Office

Rudrali Hitech Tools Pvt. Ltd.

Plot No. 113/7, 'S' Block, MIDC
Bhosari, Pune – 411026 (MAH.) INDIA

Northern Region

New Delhi

Contact : +91 88888 07065

Southern Region

Bangalore

Contact : +91 88888 07063



Manufacturing Plants...



SOLAPUR Plant

Rudrali Hi Tech Tools Pvt. Ltd.

E-94 M.I.D.C Akkalkot Road,
Solapur-413006 (MAH.) INDIA
Phone No:- +91-217 2651709/3293289



PUNE Plant

Rudrali Hi Tech Tools Pvt. Ltd.

113/7, 'S' Block, MIDC Bhosari,
Pune – 411026 (MAH.) INDIA
Phone No:- +91-020 27128590/968889992

Email:- info@rudrali.com

Visit us at :- www.rudralihitechtools.com



Thank You..!