

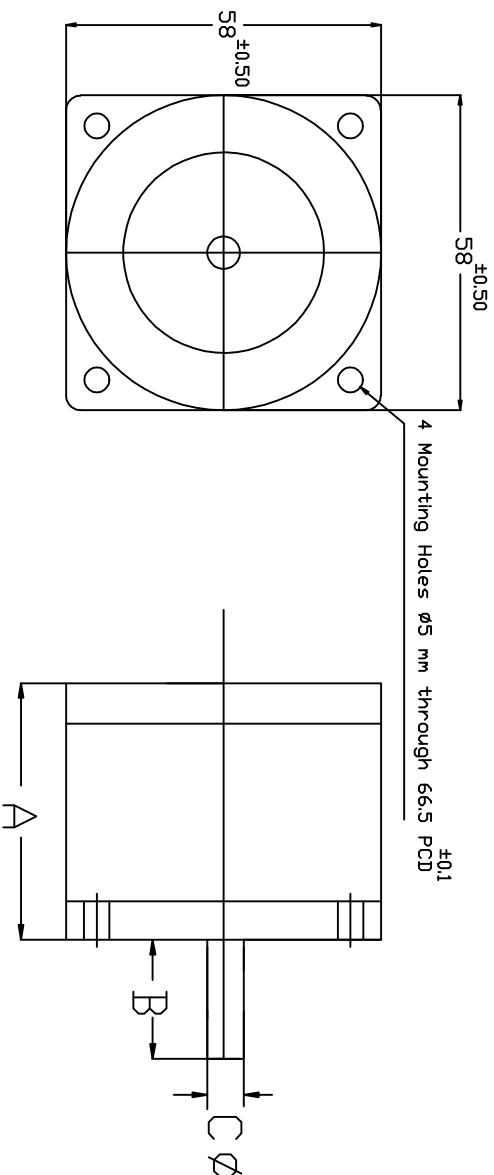

DIMENSIONAL DETAILS OF STEPPER MOTORS (600 SERIES)



SURFACE SQUARE TO SHAFT DIA WITHIN 0.080 MM,
 SHAFT RUN OUT 0.051 MAX,
 OUTPUT WIRE LENGTH 500 MM

ALL DIMENSIONS ARE IN MM
 ALL UNSPECIFIED TOLERANCE ± 0.1 MM

MOTOR TYPE SYN/STM	TORQUE Kg-Cm	A MIN/MAX	B MIN/MAX	C MIN/MAX	WT. IN KGS	PCD Ref.
601	2	52/68	17/24	$\varnothing 6/6.35$	0.700	66.5
602	4	78/98	17/27	$\varnothing 6/6.35$	1.000	66.5

Srijan Design	Description : synchronous / Stepper Motor
 <p style="font-size: 1.2em; margin: 0;">SRIJAN CONTROL DRIVES PUNE, INDIA.</p>	
Scale N.T.S	Sheet