

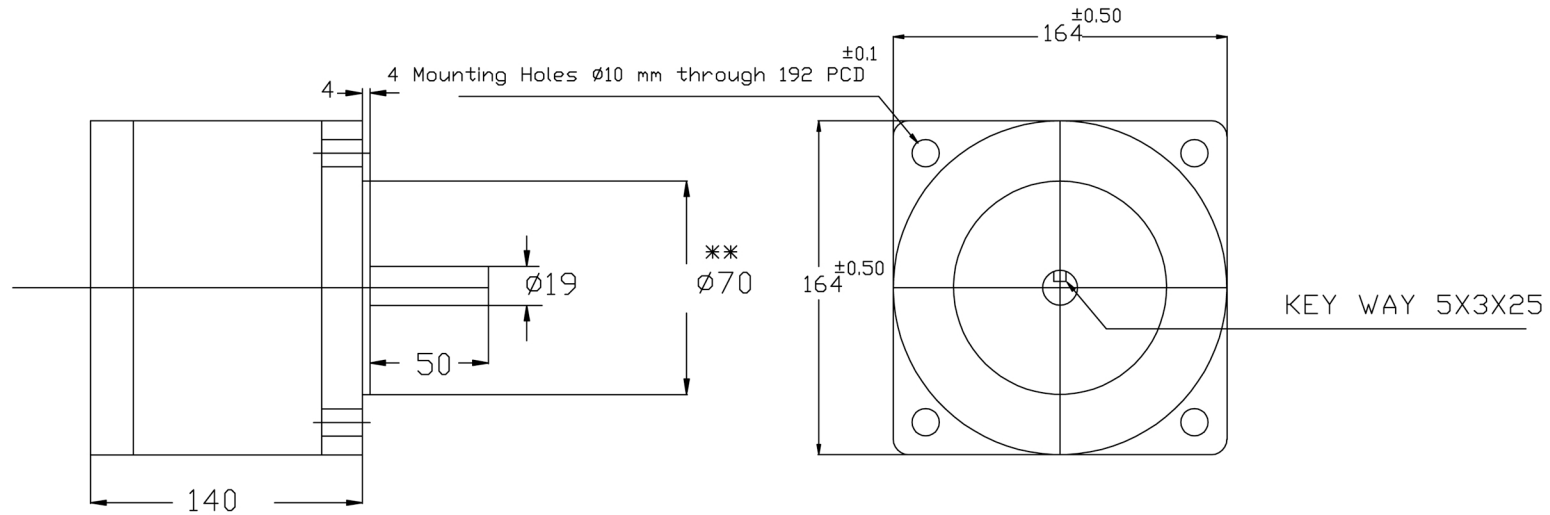

DIMENSIONAL DETAILS OF STEPPER MOTORS (1701 SERIES)



** BOSS DIAMETER - DIMENSION SHOWN APPLY BEFORE PAINTING
 SURFACE SQUARE TO SHAFT DIA WITHIN 0.080 MM,
 SHAFT RUN OUT 0.051 MAX,
 OUTPUT WIRE LENGTH 600 MM

ALL DIMENSIONS ARE IN MM
 ALL UNSPECIFIED TOLERANCE +/-0.1 MM

MOTOR DETAILS	
MOTOR TORQUE	125 Kg-cm
MOTOR WEIGHT	12 Kg

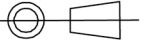
Srijan Design	Description : Stepper Motor	
	SRIJAN CONTROL DRIVES PUNE, INDIA.	Scale N.T.S
		
		Sheet