

# Liquidew EExd

## Moisture in Liquids Analyzer

The Liquidew EExd offers complete trace moisture measurement, applying a robust sensor technology to provide direct, accurate, on-line measurements for moisture dissolved in process liquids. Purpose designed explosion-proof analyzer provides single-or dual-channel measurements, convenient display interface and easy installation for new projects and retrofits to existing plants.



### Highlights

- EExd flameproof certified – ATEX,  $cCSA_{US}$  and GOST Ex
- Complete hazardous area installation
- Single or dual-channel measurements
- Moisture content, dew point and temperature
- 0.001 ppm<sub>w</sub> to saturation range capacity
- Pre-programmed and user entered saturation concentration values
- Remote global access options

### Applications

- Naptha feedstock to isomerization catalyst
- Hexane solvent in HDPE and LDPE process
- Benzene in styrene manufacture
- LNG LPG production and product checking
- Diesel and aero-fuels to avoid liquid water phase separation
- BTX process monitoring - benzene, toluene and xylene
- ... and many more

# Liquidew EExd – The Moisture in Liquid Analyser for the Modern Process Environment

Liquidew EExd is a purpose designed, certified explosion proof solution to on-line continuous moisture measurement for petrochemical liquid applications.

Liquidew EExd is installed directly in the hazardous area, simplifying site installation and retrofits. Moisture content is determined in parts per million by weight (ppm<sub>w</sub>) through Henry's Law from the measured water dew point temperature and liquid temperature. The instrument uses an extensive list of saturation concentration data preprogrammed for a variety of petrochemical liquids, with provision for easy entry of 'custom' characteristics data by the user.

Experience in sample handling and conditioning is built into the Best Practice Sampling System that completes the comprehensive factory built analyzer package. The system is ready for installation next to the sample point or point of interest in the process.

## Simple Explosionproof Installation

Liquidew EExd is a self-contained, field-based Moisture Analyzer, certified as flameproof for use in IEC Zone 1 and 2 and explosionproof NEC Class 1 Div. 1 and 2 hazardous areas. The Main Unit (electronics and sensing) and associated sampling system may be mounted at a convenient location next to the pipeline or process, with liquid sample and process return connections.

A single, low wattage single-phase AC supply is required for both the analyzer and sampling system. No barrier units or safety grounding are required, saving the user both cost and inconvenience.

## Advanced Sensor Technology

Liquidew EExd utilises the Michell Ceramic Moisture Sensor with integrated temperature measurement, offering unrivalled reliability and performance with more than 1,000 installations in natural gas and petrochemical installations world-wide.

Thick- and thin-film semiconductor technologies with metallized ceramics produce an exceedingly durable sensor, with the physical resilience to provide long-term reliable service in liquid phase measurements.

Every Liquidew EExd sensor is calibrated against fundamental dew point measurement systems in Michell's world-class laboratory, which is internationally accredited and directly traceable to both NPL (UK) and NIST (USA) base standards.

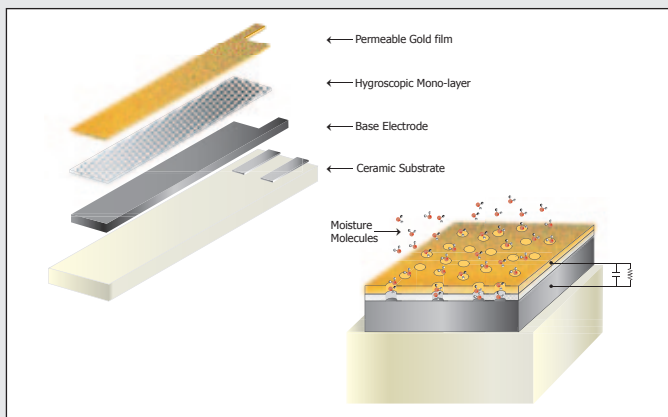

## Single and Dual Channel

Liquidew EExd is available in 1- and 2- channel versions to achieve best economy and installation convenience in fulfilling on-line moisture in liquid applications.

## Temperature Controlled for Best Accuracy

To ensure continuous optimum performance the Liquidew EExd Main Unit is internally temperature controlled at the normal maximum local environmental temperature. This greatly reduces the effect of diurnal temperature variations that would otherwise introduce transitional adsorption and desorption effects in the sample handling components and result in erroneous measurements during periods of temperature change.

The Liquidew EExd features an advanced temperature compensation algorithm that automatically maintains best possible measurement accuracy in the event of heater failure or if the prevailing climate exceeds the set temperature level.

## Calibration Maintenance Made Easy

Maintenance of traceable calibration is essential to the lifetime performance of all analyzers. Beware claims of "automatic calibration". This is a non-traceable, internal field check and does not represent a true calibration of the analyzer.

For Liquidew EExd, true calibration maintenance is simple. The unique Michell Calibration Exchange Service offers fast delivery, world-wide, of newly calibrated replacement Ceramic Sensors certified traceable to NIST and NPL. As the calibration data for the EExd Sensor is programmed into onboard non-volatile memory, fitment of a Calibration Exchange Sensor renews the calibration, with minimal down-time. No programming or data input is required by the user to complete the calibration process.

The Calibration Exchange Service facilitates a professional, scheduled user QA programme at a lower cost than a traditional 'return to manufacturer' re-calibration service. Calibration or exchange is recommended annually for innocuous liquids and six months for 'aggressive' liquids.

## Liquidew Sampling Systems

Good sample conditioning and handling is particularly important in the field of moisture measurement in liquids. The moisture sensor is directly exposed to the liquid process stream in order to detect the dissolved moisture present. Key sampling issues such as preventing particulate contamination and temperature control are critical to reliable measurements. The design of the Liquidew EExd Sampling System is the result of over thirty years of experience in on-line process moisture analyzers to optimize accuracy and repeatability.

## Comprehensive Integration

Liquidew EExd offers traditional linear analog measurement signals and user-configured alarm contacts (process moisture and analyzer status). Modbus RTU enables total integration with user's SCADA or DCS via ActiveX.

# Liquidew EExd Best Practice Sampling System



## Sampling system features

- Certified explosionproof/EExd
- Houses analyzer main unit
- Remote global access options
- User friendly display and 'touch glass' keyboard
- Outputs: alarms and analog digital communications
- $c$ CSA<sub>US</sub>, ATEX and GOST Ex approved
- Measurement Units:  
moisture content ppm<sub>w</sub>  
dew point, °C and °F  
sample temperature °C and °F
- Heating/Thermostat Options
- One or two stage sample filtration
- Optional sample cooling
- Complete hazardous area installation – indoor or outdoor
- Optional enclosure cooling
- Wide choice of standardized design options
- Non-standard customized solutions

## Liquidew EExd One Channel Flow Schematic

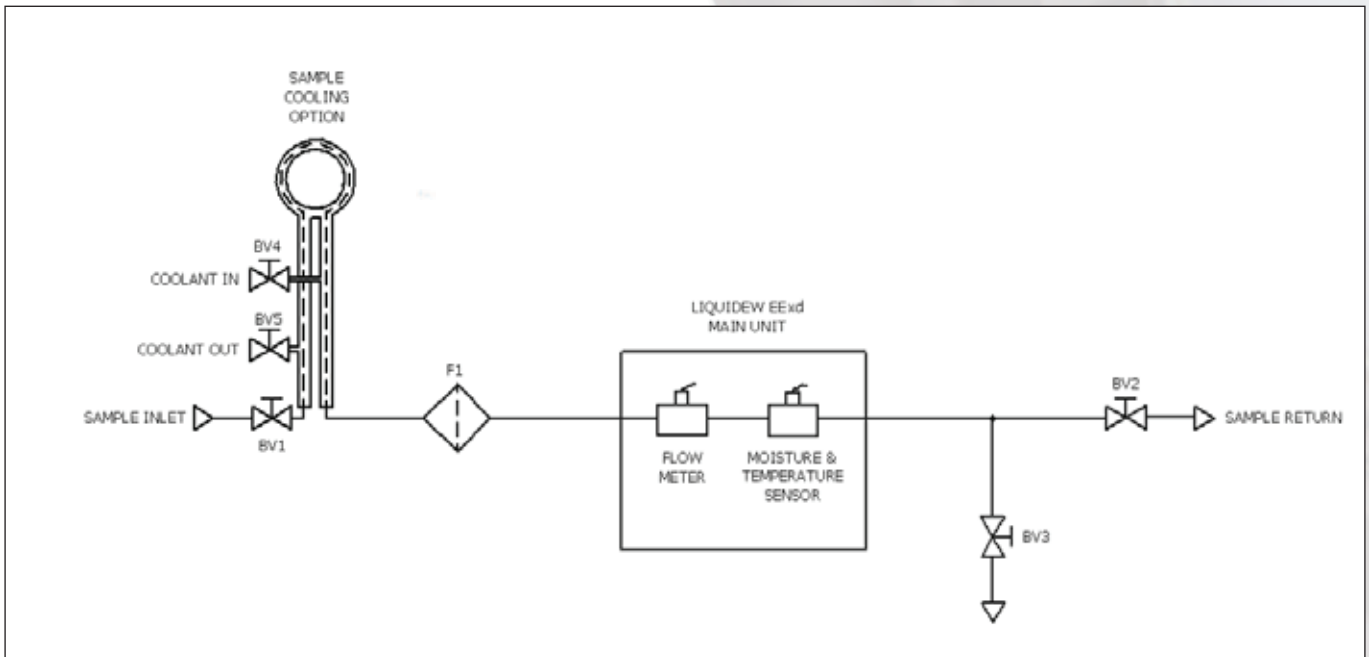



User-friendly Liquidew EExd Main Unit – 'Touch Glass' HMI alphanumeric display, menu configuration by user

## Remote Interface

For users that wish to have a dedicated host within their Control or Instrument Room, the optional Remote Interface (RI) provides advanced graphical display of measurement and status information, data logging and all programme configuration functions for up to 31 analyzers. Each analyzer communicates with the RI through the Modbus RTU, so transferring all the functionality of the Main Unit through into the comfort and convenience of an indoor safe area environment. Additionally, global access to all functionality is provided through any web browser into the embedded unique IP address of the RI.



Optional remote interface

## Application of Henry's Law

The measurement method utilised by Liquidew EExd relies on the fact that moisture dispersed within an immiscible non-polar liquid, such as a hydrocarbon, acts as a gas exerting a partial pressure of water vapour and with a corresponding dew point temperature.

With increased moisture concentration or reduced temperature, the level of saturation (saturation concentration,  $C_s$ ) can be reached specific to the fluid carrying the moisture and the prevailing temperature. Under such saturated conditions (so at a temperature below the dew point of the dispersed moisture vapour) free water globules will form within the carrying liquid.

With Liquidew EExd the amount of dissolved moisture dispersed throughout such an immiscible process liquid is measured on-line in real time in units of ppmw moisture content using Henry's Law:

$$\text{ppm}_w = C_s \times e/e_s$$

Where

- $\text{ppm}_w$  = Parts per million by weight
- $C_s$  = Saturation concentration in  $\text{ppm}_w$  specific to the fluid at the measurement temperature
- $e$  = Actual water vapour pressure derived from the measurement dew point temperature
- $e_s$  = Saturation water vapour at the measured temperature

Liquidew EExd offers a complete measurement range capability from low trace moisture below 1  $\text{ppm}_w$  right up to the saturation concentration specific to the fluid being measured at the analysis temperature.

The advanced firmware of Liquidew EExd provides moisture measurements in ppmw through the application of Henry's Law using pre-programmed saturation concentration ( $C_s$ ) values for the most common pure hydrocarbon liquid applications:

- |                       |               |
|-----------------------|---------------|
| • Hexane              | • n-Propane   |
| • Isopropylbenzene    | • Benzene     |
| • n-butane            | • i-butane    |
| • Propylene (propene) | • Cyclohexane |
| • 1-Butene            | • Octene      |

Four user-programmable tables enable Liquidew EExd to be applied to virtually any immiscible solute. For simple mixtures of solutes a proportional combination of the  $C_s$  values for two or three individual substances can be applied.

For applications with complex mixture fluids, customers can enter their own  $C_s$  values from their own library sources or from actual laboratory titration analysis of the fluid concerned.

# Technical Specifications

<b>Main Unit – Measurement Parameters</b>	
<b>Channel Configuration</b>	Single and dual channel
<b>Moisture Content</b>	ppm <sub>w</sub>
<b>Temperature</b>	°C and °F
<b>Water Dew Point</b>	°C and °F
<b>Sample Flow Rate</b>	Status indication: Low-Good-High (<0.1 to >0.3 l/min)
<b>Sensor Technology</b>	
<b>Moisture Sensor Technology</b>	Michell Ceramic Moisture Sensor
<b>Calibration Range</b>	-100°C dp to +20°C dp
<b>Measurement Range</b>	-120°C dp to +30°C dp (0.001 ppm <sub>w</sub> to saturation)
<b>Accuracy</b>	Dew point: ±1°C between -59.9 & +20°C dp Moisture content: ±10 % of reading Dew point: ±2°C between -60 & -100°C dp Moisture content: ±20 % of reading Analysis temperature: Accuracy ±0.2°C
<b>Resolution</b>	0.1°C between +20°C dp and -80°C dp 1°C between -80°C dp and -100°C dp
<b>Temperature coefficient</b>	Algorithm compensation
<b>Operating Pressure</b>	Max. 50 barg
<b>Sample Flow</b>	Up to 1 litre per minute (0.1-0.2) recommended
<b>HMI</b>	
<b>Keypad/Interface</b>	Capacitive touch-screen through glass
<b>Display</b>	Vacuum fluorescent
<b>Datalogging</b>	A rolling maximum of 150 data logs is available. Each log records time, date, moisture and temperature values for each channel. 5 minutes minimum and 60 minutes maximum logging intervals can be set by the user
<b>Communications and Output</b>	Two non-isolated 4-20 mA per measurement channel. 500 Ω maximum load. Range and parameter settable by user. Modbus RTU @ 9600 baud-rate Alarms: two volt free contacts per channel; one process value and one instrument status. Also available via Modbus communications
<b>Enclosure</b>	
<b>Type</b>	Flameproof EExd
<b>Construction</b>	Cast copper-free aluminium (IP66/NEMA 4)
<b>Finish</b>	Chromate primer, Polyester P9010 powder coated (black). Meets BS3900
<b>General</b>	
<b>Sample Connections</b>	1/4" NPT (female)
<b>Weight</b>	22.5 Kg
<b>Operating Supply Voltage</b>	90 to 260 V AC, 50/60 Hz, 180 W Main Unit
<b>Operating environment</b>	-20°C to +60°C up to 95 % RH, Indoor or Outdoor, shaded location
<b>Certification</b>	
<b>Hazardous area certification</b>	ATEX Certification: II 2 G Code: EEx d IIB + H2 T4 (135°C) IP66 Tamb -40 to +60°C cCSA <sub>US</sub> approved: Div 1, Class 1, Group B,C,D GOST Ex
<b>Pattern Approval</b>	GOST-R, GOST-K

<b>Remote Interface</b>	
Optional for indoor safe area installation	
<b>Host Capacity</b>	Up to 31 Michell EExd Process Area Installation Instrumentation Range analyzers in any combination of models via Modbus
<b>Display</b>	Backlit color 15 cm LCD
<b>User Interface</b>	Integral mouse, on-screen keyboard
<b>Function</b>	View and modify analyser operating settings. Record parameters to file and view virtual chart recorder Analyser diagnostics
<b>Ports</b>	LAN, USB2, Modbus Re-transmission
<b>Data Download</b>	CSV (comma separated variable) format for easy import to Excel™
<b>Remote Access</b>	OPC (OLE for Process Control) over a LAN Embedded web page/unique IP address for PC access. Remote data reading via modbus RTU
<b>Power Supply</b>	100-280V, 50/60Hz
<b>Plant control integration</b>	ActiveX components to be used by software programmers for integration of Modbus protocol into a general plant software system.

For details of configurations and options, please refer to the **Liquidew EExd Order Codes** list. If not appended to the end of this datasheet, copies are available from the Michell Instruments website or from your local Michell Instruments office.

# Sampling Systems

## Indoor Single Channel Galvanised Steel Panel

### Main Unit

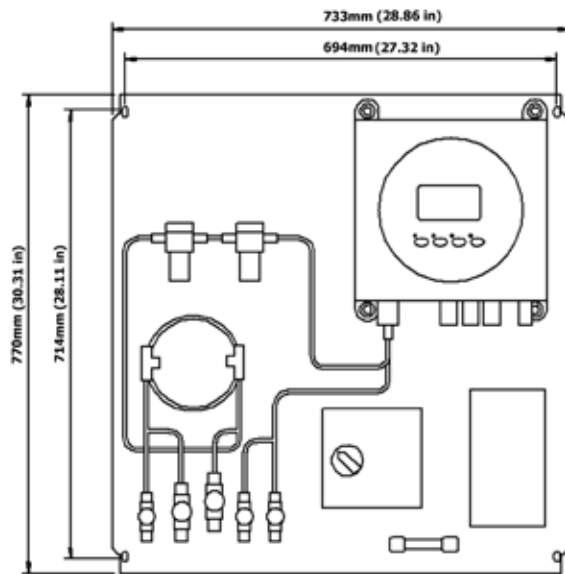
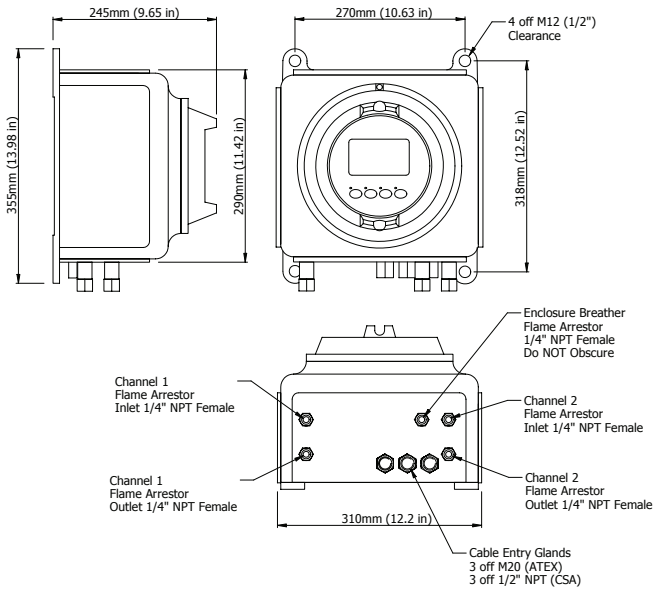

### Remote Interface

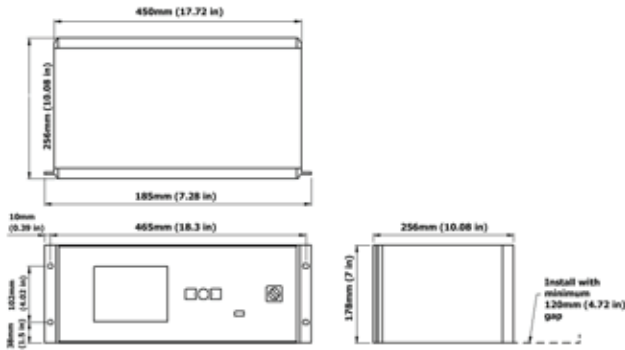

## Outdoor Single Channel Stainless Steel Enclosure

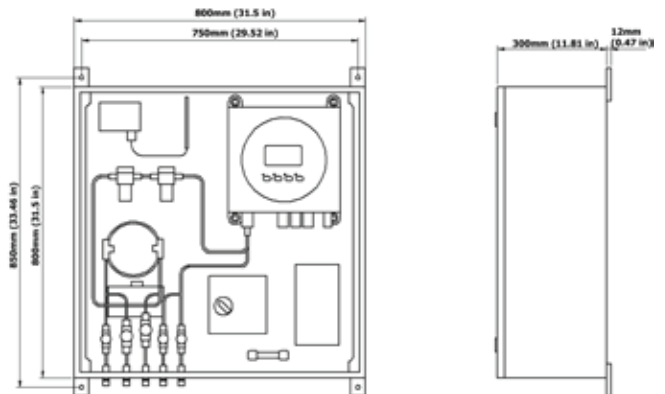

### Two channel versions

Indoor panel: 933 x 970 x 260 mm (W x H x D)

Outdoor enclosure: 1000 x 1050 x 312 mm (W x H x D)

**Michell Instruments** 48 Lancaster Way Business Park, Ely, Cambridgeshire, CB6 3NW

Tel: +44 (0) 1353 658000, Fax: +44 (0) 1353 658199, Email: [uk.info@michell.com](mailto:uk.info@michell.com), Web: [www.michell.com/uk](http://www.michell.com/uk)

Michell Instruments adopts a continuous development programme which sometimes necessitates specification changes without notice.

Issue no: Liquidew EExd\_97152\_V4\_UK\_1211