

Promet EExd

Process Moisture Analyzer

The complete moisture measurement package for critical process gas applications.



Highlights

- EExd flameproof certified - ATEX, cCSA_{US} and GOST Ex
- Complete hazardous area installation
- Single or dual-channel measurements
- Moisture content, dew point and pressure
- Calibration traceable to NPL (UK) and NIST (US)
- Range -120 to +30°C dew point, 0.001 to 30,000 ppm_v
- Remote global access options
- Sour gas compatible
- Field calibration maintenance

Applications

- Natural gas glycol dehydration
- Offshore export pipeline natural gas
- Transmission pipeline monitoring
- LNG production
- Catalytic reformer recycle hydrogen
- Ethylene feed stock to polymer plant
- Speciality gas production
- ... and many more

Promet EExd – The Moisture Analyzer for the Modern Process Environment

For the last thirty years, Michell Instruments has provided on-line moisture measurement solutions for the natural gas and petrochemical industries. All of that experience and expertise is encapsulated in Promet EExd, where the highest priorities have been given to the needs of the customer in terms of simplicity of installation, total plant communications integration, moderate cost of ownership, and highest calibration integrity.

Promet EExd offers single and dual channel moisture measurement, with integrated electronic pressure reading, within a single field-installed flameproof housing. User interface is provided through the bright vacuum fluorescent display and touch screen switches.

Comprehensive Sampling Systems of state-of-the-art design, with best practice sample filtration, pressure reduction and flow control, and a range of options are available to fulfil user specific installation and application requirements.

Simple Flameproof Installation

Promet EExd is flameproof certified for use in IEC Zone 1 and 2/NEC Class 1 Div. 1 and 2 hazardous areas. The Main Unit (electronics and sensing) and associated sampling system may be mounted at a convenient location next to the pipeline or process, with gas sample and vent connections. A single, low power single-phase AC supply is required for both the analyzer and sampling system. No barrier units or safety earth are required, saving the user both cost and inconvenience.

Advanced Sensor Technology

Promet EExd utilises the Michell Ceramic Moisture Sensor, offering unrivalled reliability and performance with more than 1,000 installations in natural gas and petrochemical installations world-wide.

Thick- and thin-film semiconductor technologies with metallized ceramics produce an exceedingly durable sensor, with measurement sensitivity to 10 ppb_v moisture content and high-pressure capability up to 206 barg (2988 psig).

Unlike older aluminium-oxide technologies, the inherent immunity to pressure shock of the Ceramic Sensor completely avoids any risk of sensor failure at commissioning or shut-down, whilst the unique inert nature of the sensor gives unrivalled long-term resistance to chemical attack, even in extremely sour gas with percentage level H₂S concentrations.

The Ceramic Sensor responds to the partial pressure of water vapour in the gas being measured, which is directly related to the dew point temperature. Every Promet EExd sensor is calibrated against fundamental dew point measurement systems in Michell's world-class laboratory, which is internationally accredited and directly traceable to both NPL (UK) and NIST (USA) base standards. Precise process moisture measurement with a class leading best accuracy of ±10% of measured value is assured.

Comprehensive Measurement Units

Promet EExd offers complete flexibility for the user to select the preferred hygrometric unit, be it dew-point temperature in °C or °F, or an exhaustive list of moisture content units. Integral pressure measurement enables unit conversions from dew point to moisture content, or dew point to dew point for different pressure conditions.

The firmware of Promet EExd incorporates conversion data for ideal gases and also specific to natural gas, using either the long established IGT Research Bulletin No. 8 or the more recently published ISO 18453, to customer order preference.

Calibration Maintenance Made Easy

Maintenance of traceable calibration is essential to the lifetime performance of all analyzers. Beware claims of "automatic calibration". This is a non-traceable, internal field check and does not represent a true calibration of the analyzer.

For Promet EExd, true calibration maintenance is simple. The unique Michell Calibration Exchange Service offers fast delivery, world-wide, of newly calibrated replacement Ceramic Sensors certified traceable to NPL and NIST. As the calibration data for the Promet EExd Sensor is programmed into on-board non-volatile memory, fitment of a Calibration Exchange Sensor renews the calibration with minimal downtime.

No programming or data input is required by the user to complete the calibration process. The Calibration Exchange Service facilitates a professional, scheduled user QA programme at a lower cost than a traditional 'return to manufacturer' re-calibration service.

Calibration or exchange is recommended annually for sweet gases and six-monthly for sour gases. Field calibration, using a portable dew point generator (ASTM D5454), against a calibrated reference hygrometer or against certified moisture-in-gas cylinders is also possible. Promet EExd accommodates such needs within the operating firmware, providing user-friendly access to the calibration characterisation table to allow adjustments to be made at just one point (for example using a certified moisture in gas cylinder) or multiple points (using a field generator) across the measurement range.

Temperature Controlled for Best Accuracy

To ensure continuous optimum performance, the Promet EExd Main Unit is internally temperature controlled at the normal maximum local environmental temperature. This greatly reduces the effect of diurnal temperature variations that would otherwise introduce transitional adsorption and desorption effects in the sampling system components and result in erroneous measurements during periods of temperature change.

In addition the Promet EExd features an advanced temperature compensation algorithm that automatically maintains best possible measurement accuracy in the event of heater failure or if the prevailing climate exceeds the set temperature level.

Promet EExd Premium Sampling System



Analyzer/sampling system features

- Certified explosionproof/EExd
- Houses analyzer main unit
- Remote global access options
- User friendly display and 'touch glass' keyboard
- Outputs: alarms and analog digital communications
- CSA US, ATEX and GOST Ex approved
- Measurement Units:
moisture content ppm_v (ideal gas/natural gas)
lbmmscf and mg/m³ for natural gas
dew point, °C and °F
sample pressure, barg, MPa and psig
- Heating/Thermostat Options
- One or two stage sample filtration
- Optional sample cooling
- Complete hazardous area installation – indoor or outdoor
- Optional enclosure cooling
- Wide choice of standardized design options
- Non-standard customized solutions

Trace Moisture Sampling System - Single Channel

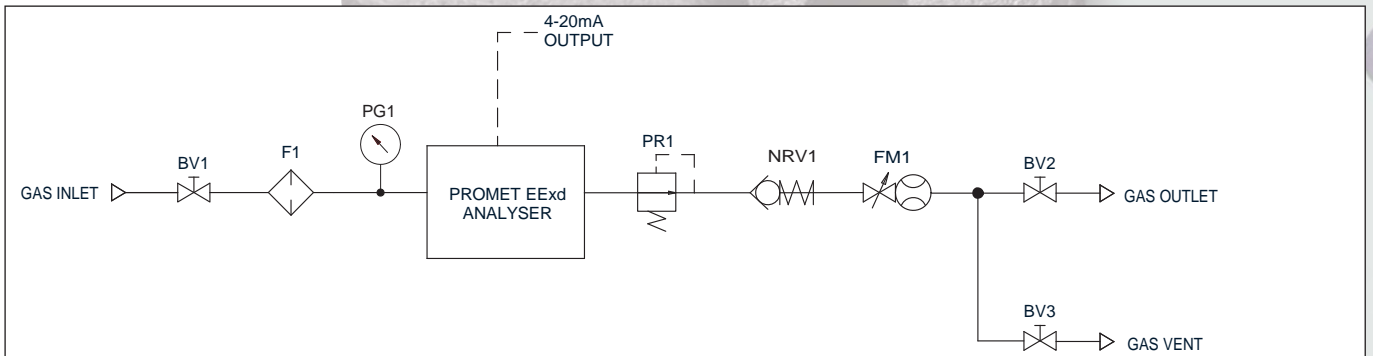

Natural Gas Sampling System - Single Channel, High Pressure

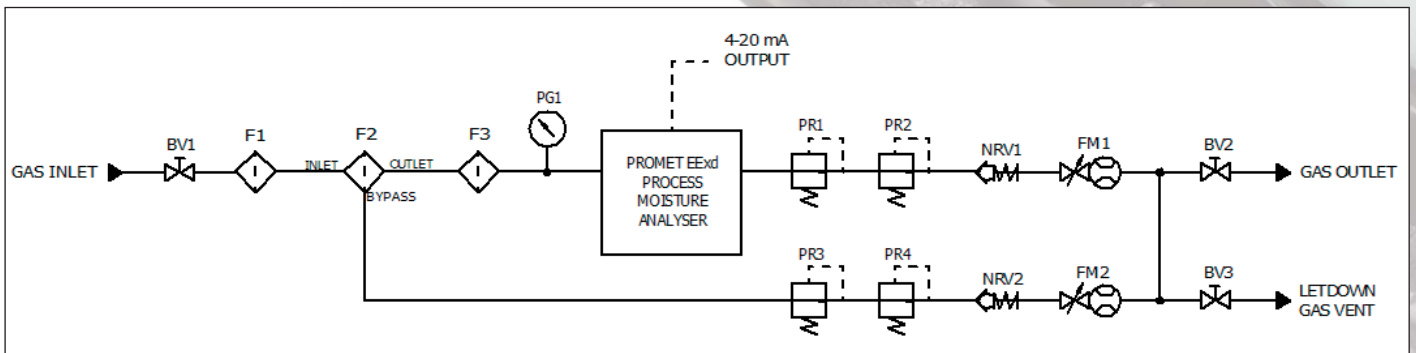



Promet EExd Main Unit Only – 'Touch Glass' HMI alphanumeric display, menu configuration by user

Communication Capability for Total Plant Integration

Promet EExd offers digital and analogue communications as standard.

- Modbus RTU is provided with optional Active X controls for integration to site SCADA/DCS.
- Two non-isolated 4-20 mA outputs per channel are user configurable for unit and range of measurement.
- Process alarm contacts can be set by the user.
- Instrument status alarms provide a continuous 'health check' through to the site control room.
- Low sample flow alarms are available as an option. Such individual alarm states are identified through the Modbus instrument registers and appear locally on the display.
- Field cable connections are conventional instrumentation pairs for all signals and alarms.

Remote Interface

For users that wish to have a dedicated host within their Control or Instrument Room, the optional Remote Interface (RI) provides advanced graphical display of measurement and status information, data logging and all program configuration functions for up to 31 analyzers. Each analyzer communicates with the RI through the Modbus RTU, so transferring all the functionality of the Main Unit through into the comfort and convenience of an indoor safe area environment. Additionally, global access to all functionality is provided through any web browser into the embedded unique IP address of the RI.

Premium Sampling Systems

Good sample conditioning and handling is particularly important in the field of moisture measurement. As the moisture sensor has to be exposed directly to the process gas stream in order to detect the water vapour present, then key sampling issues such as the avoidance of particulate and liquid contamination are imperative to successful operation. Our 30 years of expertise in on-line process gas analyzers are used to optimise the design of the Promet EExd Premium Sampling Systems.

Two core configurations, both available in either single- or dual-channel version, are available for key applications:

Natural Gas Processing and Transmission Sampling Systems

The reliable solution for glycol dehydration processes offshore and onshore and for onward pipeline transmission of sales gas. The most advanced filtration techniques with micro-porous membrane and continuous by-pass flow remove and dispose of all liquid phase contaminants. A glycol adsorption cartridge removes residual vapour that may otherwise interfere with the moisture signal.

Trace Moisture in Hydrocarbon Gas Sampling System

An optimised design for continuous trace moisture measurement in low ppm_v and ppb_v ranges for molecular sieve dehydration of natural gas prior to cryogenic liquefaction. Also suitable for many other monitoring applications at trace moisture levels in refinery gases and critical petrochemical processes. A minimalist approach to the sampling system design is essential to ensure best dynamic response to process moisture variations. A particulate filter and isolation valve are the only components prior to the sensor. As measurements are made at pipeline conditions, no regulators or other complex upstream components are necessary so ensuring the Promet EExd remains in continuous equilibrium with the process gas condition without any significant response lag.

Custom Design Service

Custom design sampling systems are available for other specific applications such as higher pressure processes and hydrogen recycle gas moisture measurement in catalytic reformer refinery processes. Your Michell office or authorised distributor will be pleased to discuss your specific application/installation requirements.



Remote Interface

Technical Specifications

Channel Configurations	Single and two channel
Moisture Parameters	Dew point °C and °F
Moisture Content	Automatic pressure compensated conversions: ppm _v for natural gas and ideal gas, lbmmscf and mg-m ⁻³ for natural gas. Dew point at a pressure input by the user for natural gas and ideal gas. Calculations for natural gas moisture content based on either ISO 18453 or IGT#8 to customer order preference.
Analysis Pressure	barg, MPa and psig
Sensor Technology	Michell Ceramic Moisture Sensor
Measurement Range	-120°C dp to +30°C dp 1 ppb _v to 30,000 ppm _v 0 to 250 barg
Calibration Range	-100°C dp to +20°C dp 10 ppb _v to 23,000 ppm _v
Accuracy	Dew point: ±1°C between -59.9 & +20°C dp Moisture content: ±10 % of reading Dew point: ±2°C between -60 & -100°C dp Moisture content: ±20 % of reading Analysis Pressure: ±0.25 % FS.
Measured Resolution	0.1°C: -80 to +20°C dp 1°C: -100 to -80°C dp
Displayed Resolution	Dew point: 0.1°C Moisture content: autoscale, 5 digits MPa and BarG: 0.1, psig: 1.0
Resolution	0.1°C between +20°C dp and -80°C dp 1°C between -80°C dp and -100°C dp
Temperature Coefficient	Algorithm compensation
HMI: Keyboard Interface	Capacitive touch-screen through glass
Display	Vacuum fluorescent
Datalogging	A rolling maximum of 150 data logs is available. Each log records time, date, moisture and pressure values for each channel. 5 minutes minimum and 60 minutes maximum logging intervals can be set by the user
Communications and Output	Two non-isolated 4-20 mA per measurement channel. 500 Ω maximum load. Range and parameter settable by user. Modbus RTU @ 9600 baud-rate. Alarms: two volt free contacts per channel; one process value and one instrument status. Also available via Modbus communications
Main Unit Enclosure	Internal temperature control for condensation protection and stable analysis conditions
Type	Flameproof EExd
Construction	Cast copper-free aluminium
Finish	Chromate primer, Polyester P9010 powder coated (black). Meets BS3900
Operating Pressure	Max. 206 barg
Sample Connections	1/4" NPT (female)
Sample Flow Rate	0.5 to 5.0 litres per min
Sample Flow Alarm	Optional
Power Supply	90 to 260 V AC, 50/60 Hz, 180 W Main Unit
Operating Environment	Indoor/Outdoor -20°C to +60°C Max 95 % rh. Shaded location
Certification	
Hazardous Area Certification	ATEX Certification: II 2 G Code: EEx d IIB + H ₂ T4 (135°C) IP66 Tamb -40 to +60°C (-40 to +140°F) cCSA _{US} approved: Div 1, Class 1, Group B,C,D GOST Ex
Pattern Approval	GOST-R, GOST-K, ukrSEPRO

Remote Interface

Optional for indoor safe area installation host capacity	Up to 31 Michell EExd Process Instrumentation Range analyzers in any combination of models via Modbus
Display	Backlit color 15 cm/6" LCD
User interface	Integral mouse, on-screen keyboard
Function	View and modify analyzer operating settings. Record parameters to file and view virtual chart recorder Analyzer diagnostics
Ports	LAN, USB2
Data Download	CSV (comma separated variable) format for easy import to Excel™
Remote Access	OPC (OLE for Process Control) over a LAN Imbedded web page/unique IP address for PC access
Power Supply	100-280V, 50/60Hz

For details of configurations and options, please refer to the **Promet EExd Order Codes** list. If not appended to the end of this datasheet, copies are available from the Michell Instruments website or from your local Michell Instruments office.

Sampling Systems

Indoor Single Channel Galvanised Steel Panel

Main Unit

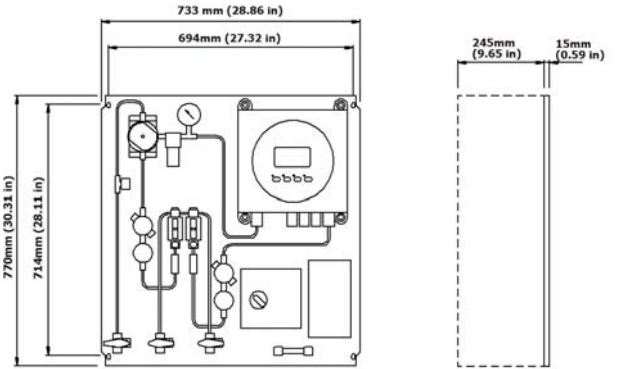
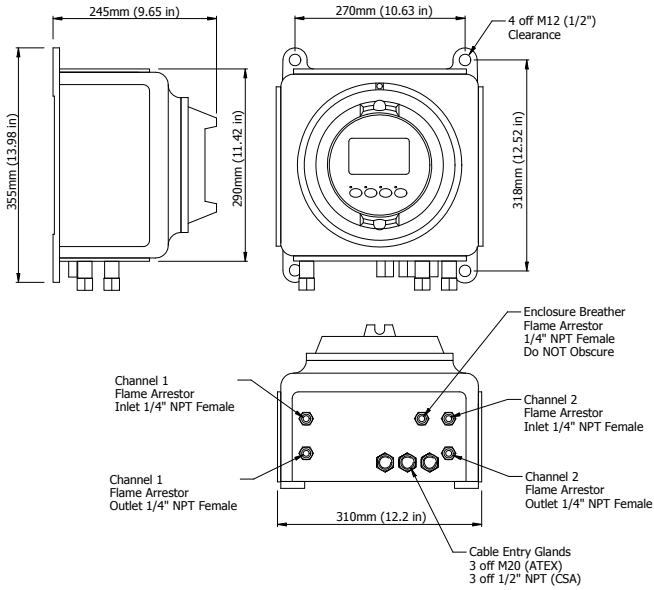

Outdoor Single Channel Stainless Steel Enclosure

Remote Interface

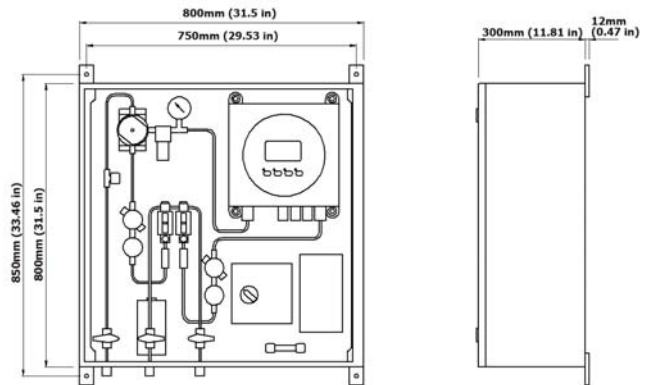
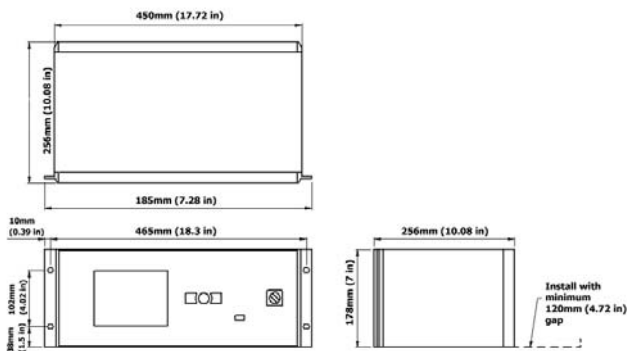

Two channel versions

Indoor panel: 933 x 970 x 260 mm (W x H x D)

36.7 x 38.1 x 10.2 inches (W x H x D)

Outdoor enclosure: 1000 x 1050 x 312 mm (W x H x D)

39.3 x 41.3 x 12.3 inches (W x H x D)

Michell Instruments 48 Lancaster Way Business Park, Ely, Cambridgeshire, CB6 3NW

Tel: +44 (0) 1353 658000, Fax: +44 (0) 1353 658199, Email: uk.info@michell.com, Web: www.michell.com/uk

Michell Instruments adopts a continuous development programme which sometimes necessitates specification changes without notice.

Issue no: Promet EExd_97151_V3.1_UK_0514