



Utech Projects Pvt. Ltd.



Solid Fuel Fired Three Pass Packaged Steam Boiler



3-PASS FULLY
WET BACK



AIR BAG FILTER &
DUST COLLECTOR



- ◆ 500 kgs/hr to 6000 Kgs/hr Steam Generator.
- ◆ 10.54 Kgs/cm² Pressure to 17.5 Kgs/cm² & above.
- ◆ Fuel – Briquette/Wood/Coal.
- ◆ Efficiency of more than 75% with heat recovery system.
- ◆ Internal Furnace & Smoke Tubes submerged in water.
- ◆ Heater Recovery System (Water/Air)

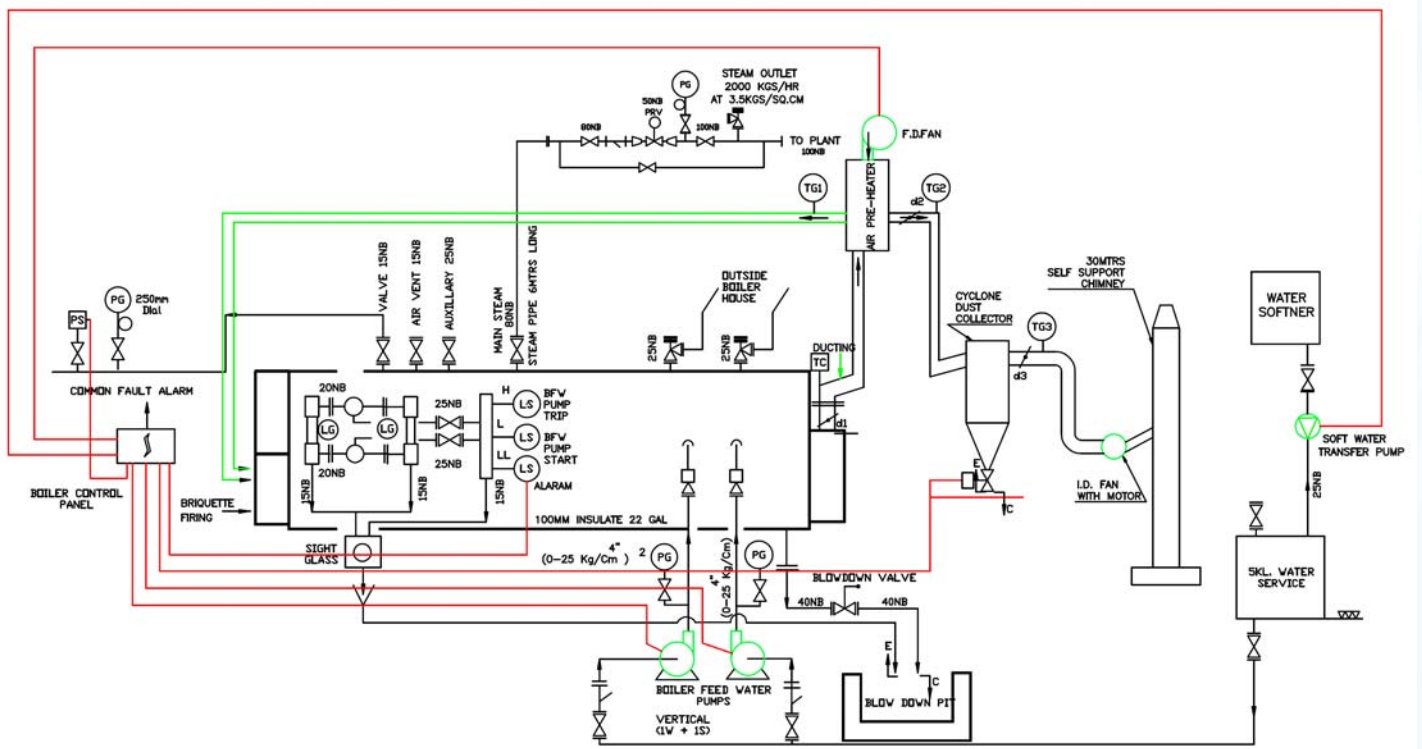

Solid Fired IBR Steam Boiler Standard P & I Diagram

CONSTRUCTION

Our boilers are manufactured in accordance with the stringent standards laid by the Indian Boiler Regulation codes. The boilers are so designed to guard against excessive thermal stresses. The boilers are manufactured using boiler quality steel plate and tubes. The quality is ensured in the manufacturing process itself which reduces rejections and reworks. All the longitudinal and circumferential seams are X-ray inspected and the boilers are stress relieved as per IBR regulation before hydro testing.

Energypack Solid fuel fired packaged boilers are specially designed for manual operation. The Furnace is fitted with specially designed heat resistant fire bars. Solid fuels are feed Manually on the bars.

ELECTRICAL CONTROLS

Fully dust proof control panel houses all the relays and controls required for the safe operation of the boiler and its accessories. Adequate overload protection is provided to ensure that motors do not get overheated.

STANDARD SCOPE OF SUPPLY

- ◆ Boiler with furnace, internal reversing chamber, smoke tubes and fusible plug manufactured, tested and certified with front and rear smoke boxes, mounted on saddle for easy installation, one set of heat resistant cast iron fire bars and cast iron doors are part of supply.
- ◆ One induced draught fan with motor.
- ◆ Two sets of feed water pumps motors, pipeline and check valves are provided.
- ◆ One set of boiler mountings with IBR certificates .
- ◆ Automatic water level controller.
- ◆ Control panel with cables upto individual motors.

OTHER PRODUCTS

IBR & NON IBR STEAM BOILERS

- ◆ Self Supported Chimneys.
- ◆ Hot water Boilers.
- ◆ Heat Exchangers (TEMA).
- ◆ Pressure Vessels (ASME).
- ◆ Waste Heat Boilers.
- ◆ Electrode Boilers.
- ◆ Dewaxing Autoclave Boilers.
- ◆ Incinerators.



Husk Fired Boiler



Membrane Wall SIB boiler



Brette Firing Boiler



Utech Projects Pvt. Ltd.

Authorised Exclusive Marketing Agency

of



M/S ENERGYPACK BOILERS PVT LTD

Office :
UTECH PROJECTS PVT LTD.

9/10, Dattani 5A, Shivaji Road,
Kandivali (West), Mumbai - 400067.
Maharashtra, India.

Telefax: +91 - 22 - 28642832 / 28642833

E mail : utechprojects@gmail.com
sales@utechprojects.com

Website : www.utechprojects.com



Registered Office & Works of Principle Manufacturer:
ENERGYPACK BOILERS PVT LTD.

24-P, Baska - Uijeti Road, Village Uijeti,
Taluka: Halol, Jilla, Panchmahal, Gujarat - 389350.

Telefax: +91 - 02676 - 247055 / 247247
Mumbai Off No: +91 22 26854233 / 26854957

E mail : uday@energypackboilers.com
response@energypackboilers.com

Website : www.energypackboilers.com